

# 35211

產品編號: 35211

# scale 1/35

1:35 比例

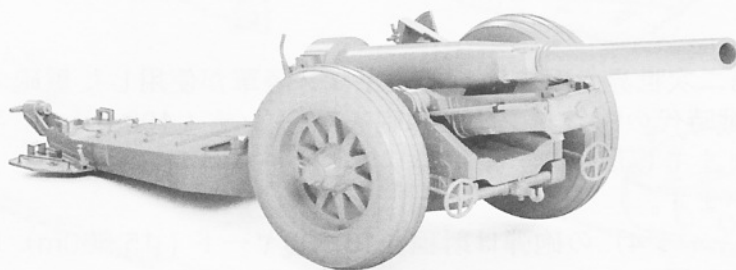

## 1/35 British 7.2 Inch Howitzer

Go through this assembly guide and understand it before you start kit assembly  
 You can download PDF assembly instruction file from our website to see closely zoomed assembly details  
 Use usual plastic kit's cements and tools (not included in the kit)  
 Follow painting guide supplied, use only hobby paints  
 Work carefully with photo etched parts if included, use C/A glues to assemble them

請您在組裝此產品前仔細閱讀組裝指南;  
 請使用通用塑膠模型黏合劑和工具(本產品不附帶);  
 本產品所以提供的噴塗指南只適用本於模型;  
 如果本產品含有蝕刻套件,請小心仔細處理, 請使用C/A膠水組裝;

組み立て前にこの組み立てガイドをご覧ください。  
 プラスチックキット専用接着剤と専用工具をご使用ください。(ともにキットには含まれていません)  
 塗装ガイドに従ってください。専用塗料をご使用ください。  
 エッチングパーツの組み立ては細かいパーツのため注意が必要です。また接着には瞬間接着剤を使用してください。



cut/remove 切下 / 移除 切断/切り離し



drill hole 鑽孔 ドリル穴



no glue 不適用膠水 接着しない



bend 折彎 折り曲げ



C/A cyanoacrylate glue 氰基丙烯酸酯膠水 瞬間接着剤



string or wire 細繩或者金屬絲線 糸または金属線



rope 繩 ひも



paint area during assembly (ref. to AMMO colors) 裝配過程中的噴漆區域推薦 (請參考AMMO顏色) 組み立て時の塗装部分 (コード例: AMMOカラー)



PE - press rivets (lines) 蝕刻片 - ラインやリベット部分を未エッチング面から圧を与える  
 from the etched off side 請从蚀刻掉的一侧压铆钉 (线)

The BL 7.2 inch howitzer was a heavy artillery gun used by the British Army throughout World War II. From 1940 the World War I era BL 8-inch howitzers were re-lined to 7.2 inches (180 mm) and the old carriages were retained although the original steel rimmed wheels were replaced with new balloon tyre wheels. The new four charge ammunition increased the range to 16,900 yd (15,500 m), but when fired the recoil caused the weapon to rear violently and jump backwards. To help eliminate this ramps were placed behind the wheels. The Scammell Pioneer Artillery Tractor R100 was usually used as a gun tractor for the 7.2-inch howitzer in the early war years

BL 7.2インチ榴弾砲は、第二次世界大戦を通じてイギリス陸軍が使用した重砲です。1940年から第一次世界大戦時代のBL 8インチ榴弾砲を7.2インチ（183mm）に手直しされ、キャリッジは旧式なままでしたがスチール製リムホイールは新しいバルーンタイヤホイールに置き換えられています。新しくなった装薬4号（チャージ4）の砲弾は射程を16,900ヤード（15,500m）に伸ばしましたが、発射時の反動により激しく後に跳躍することになりました。そのため、跳躍を軽減するためのランプ（傾斜路）が車輪の後ろに配置されることになりました。スキャメル パイオニア アーティラリートラクターR100は7.2インチ榴弾砲のガントラクターとして、戦争初期に使用されていました。

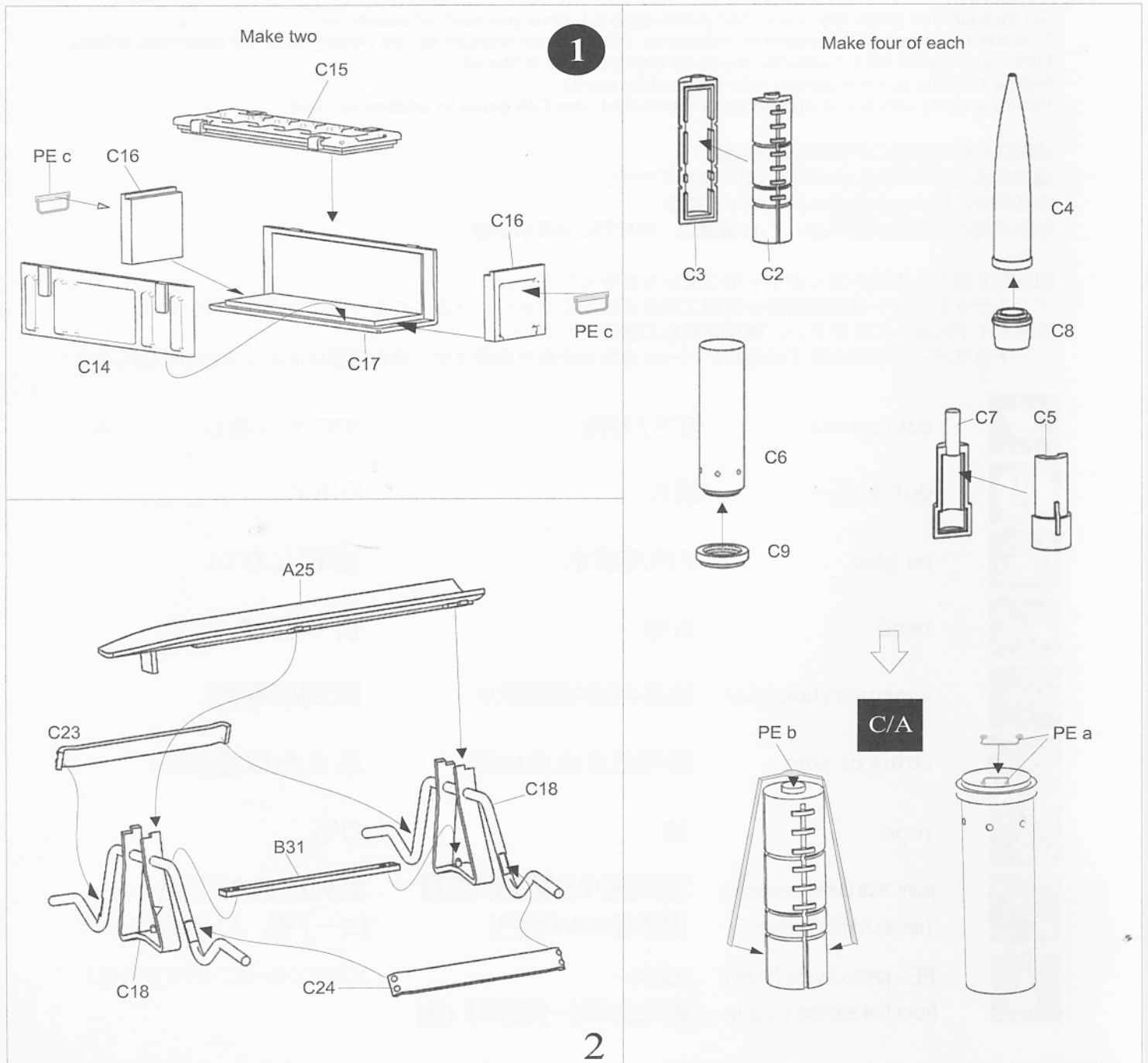

Chassis frame parts are delicate, work carefully and glue in short sections checking fit and joints through whole step

2

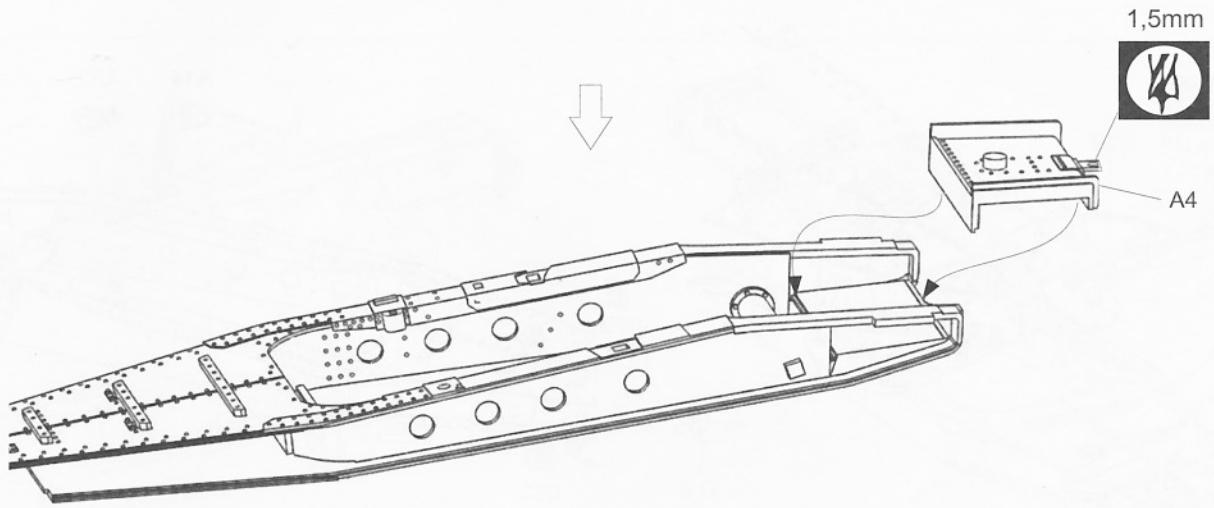
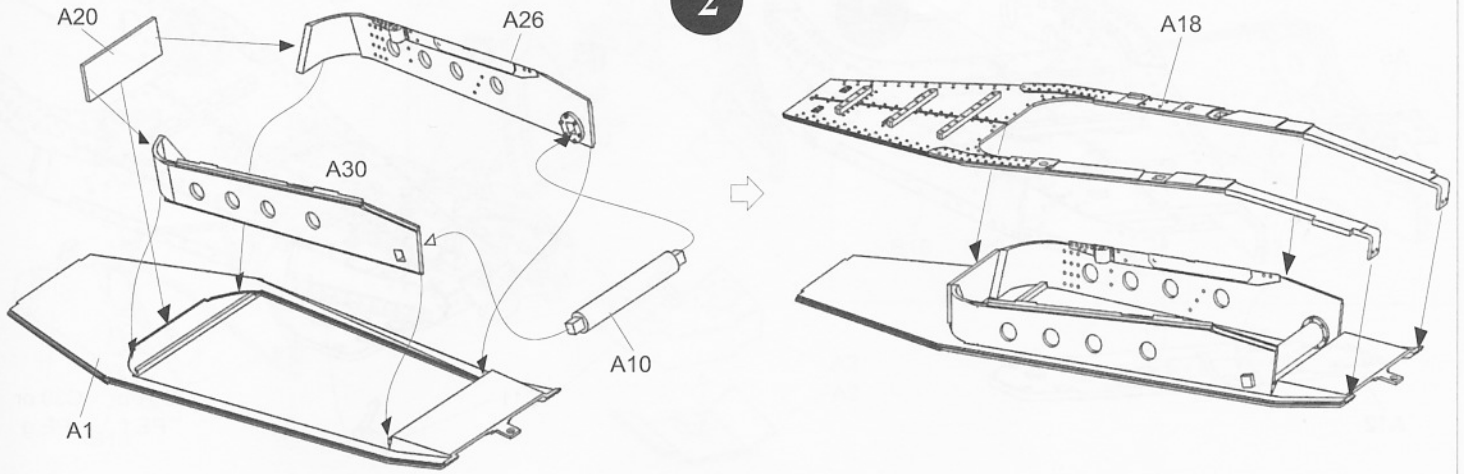

1,5mm



A4

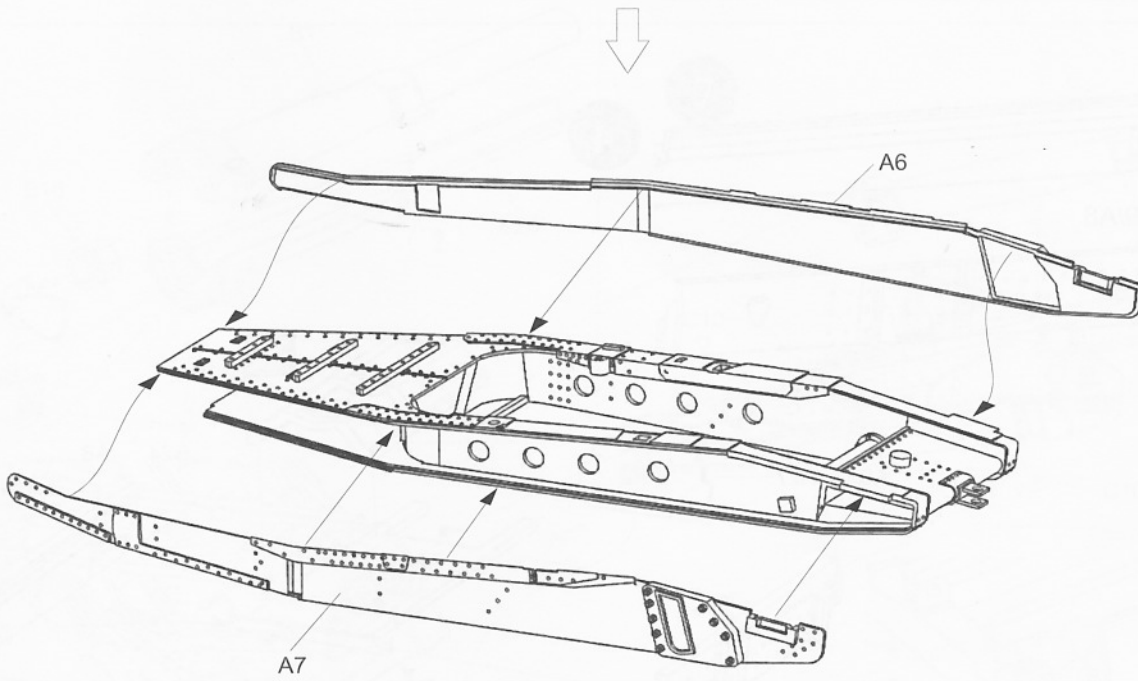

3

3

2

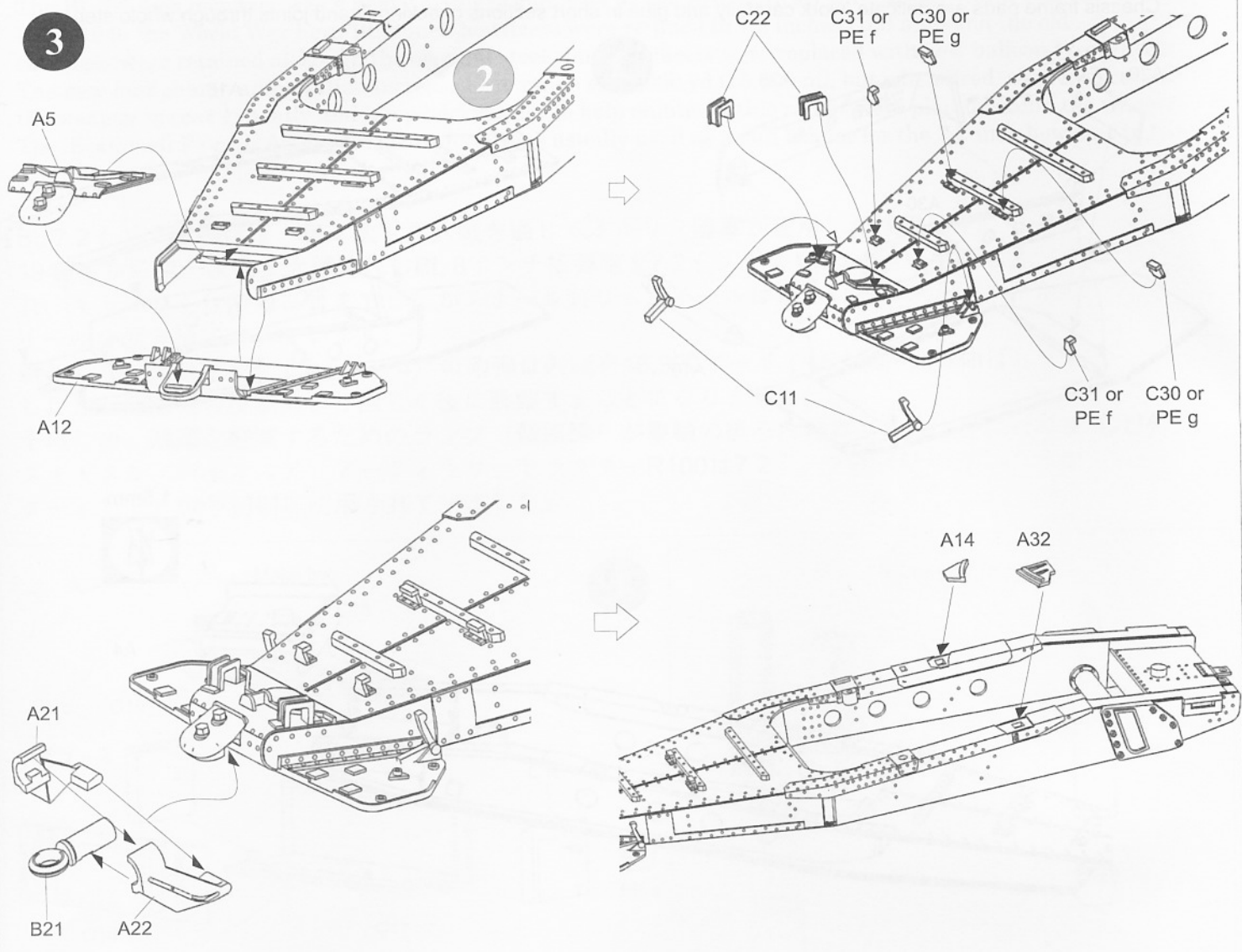

4

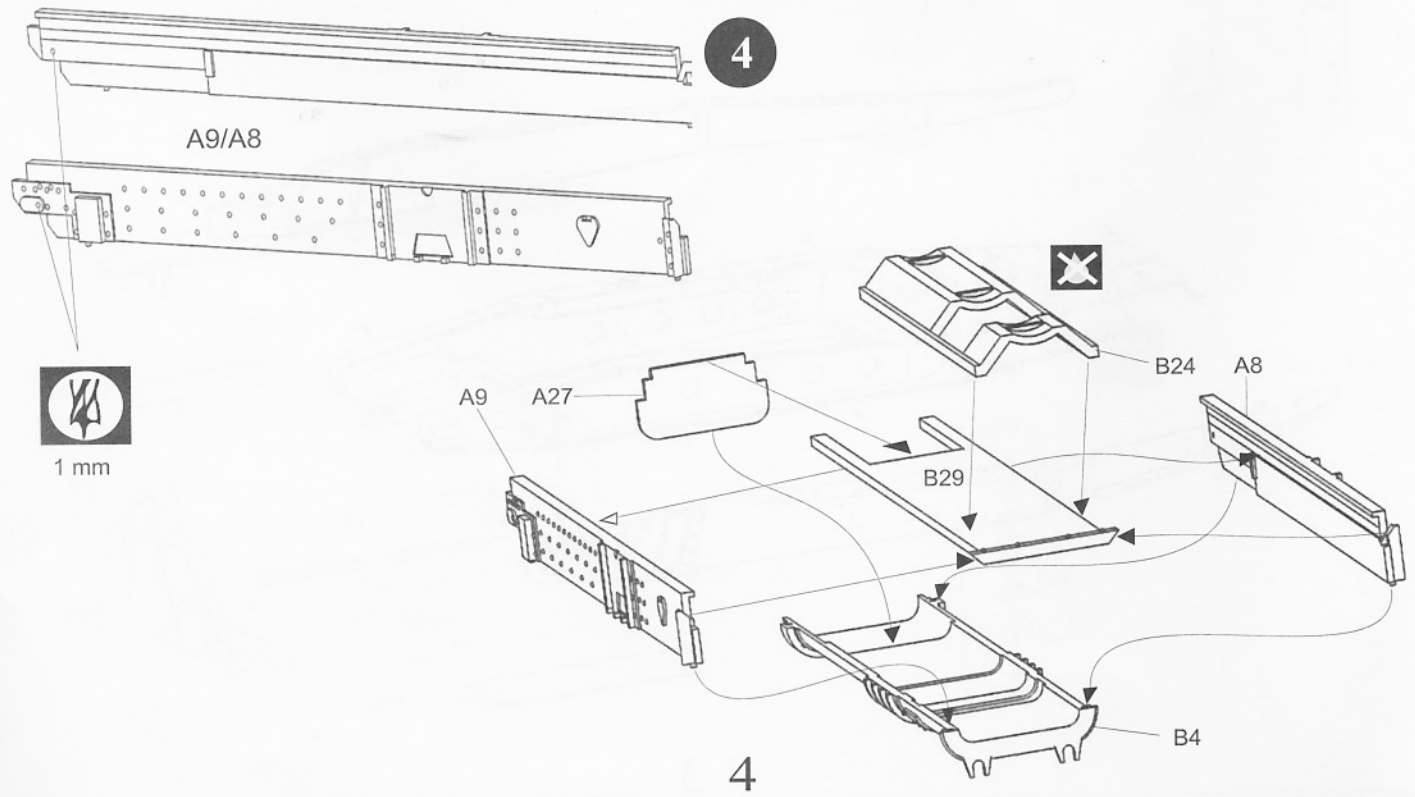

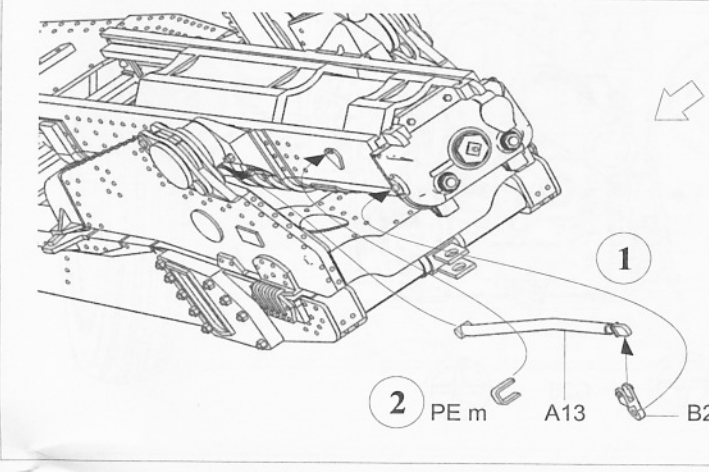
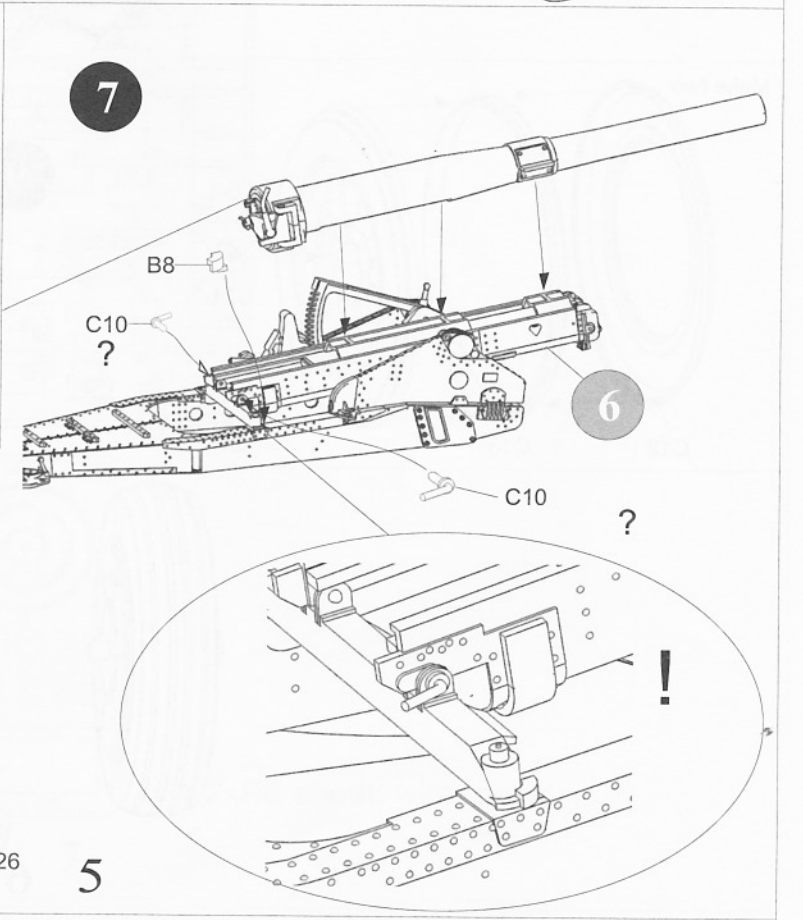
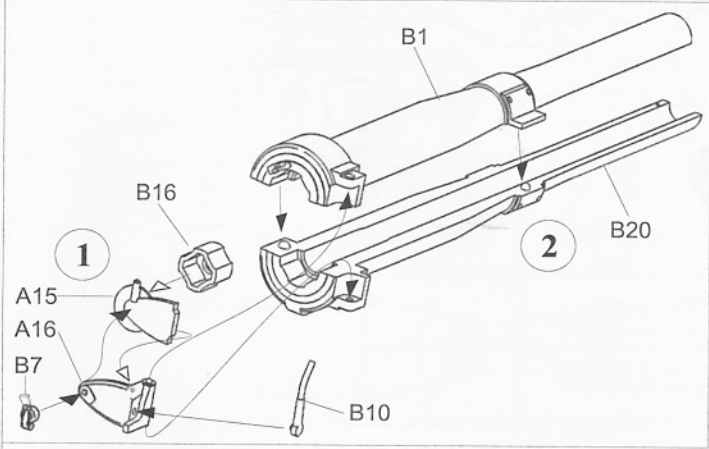
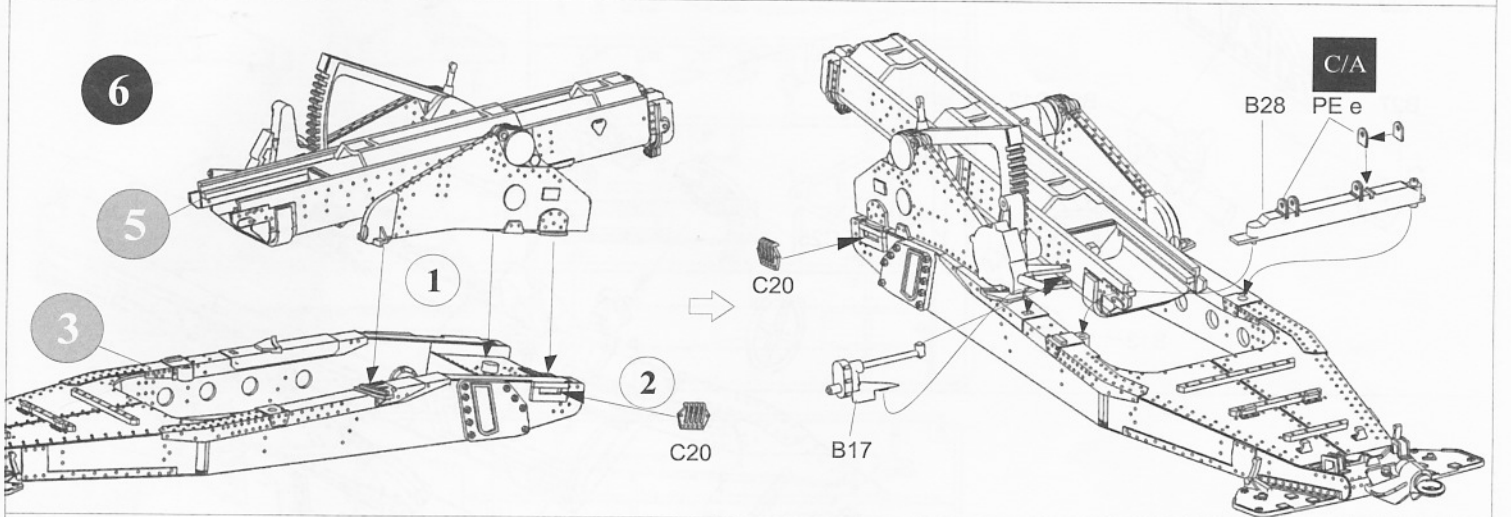
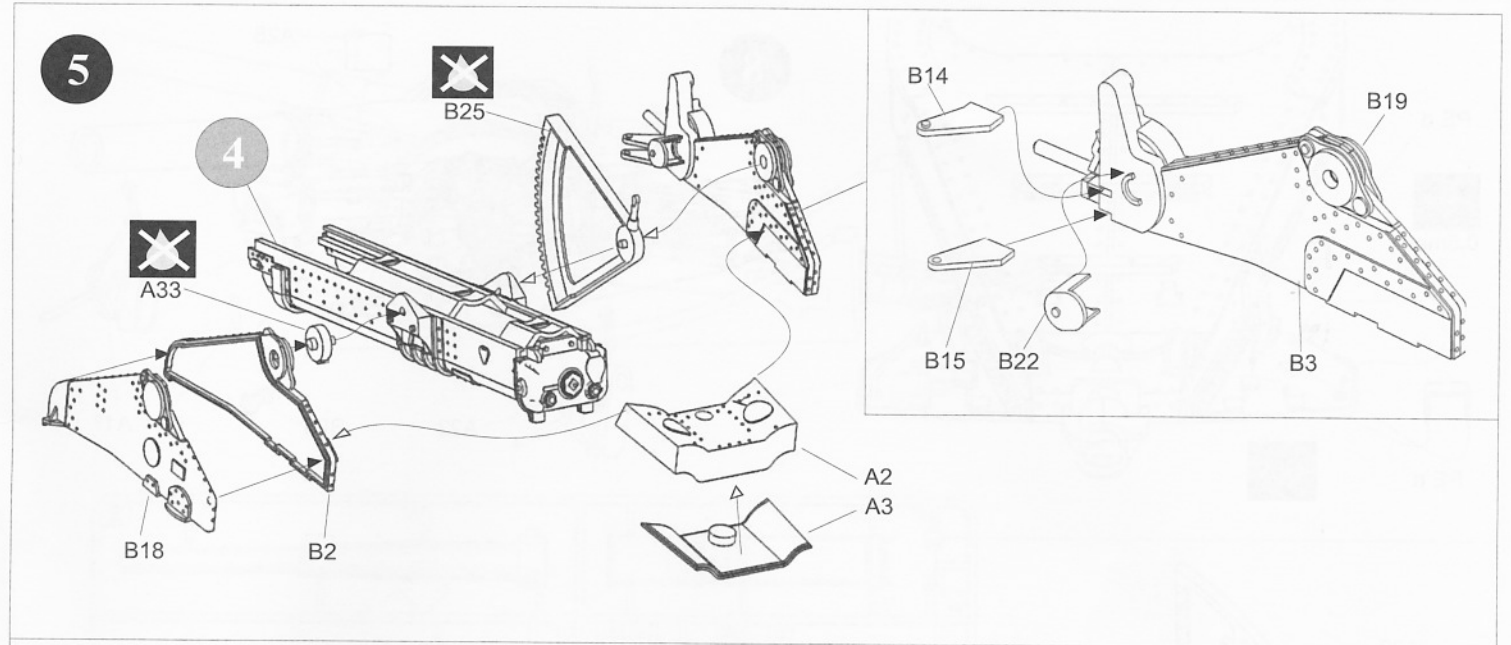

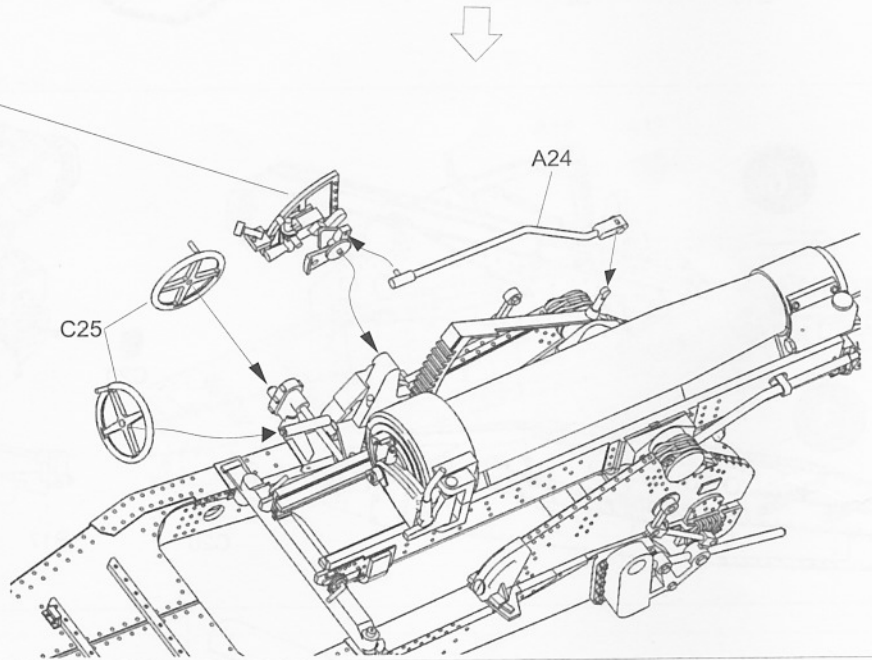
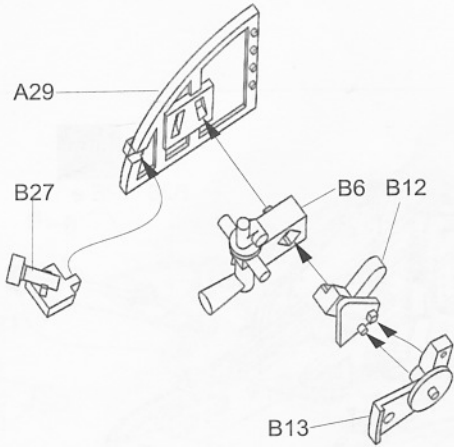
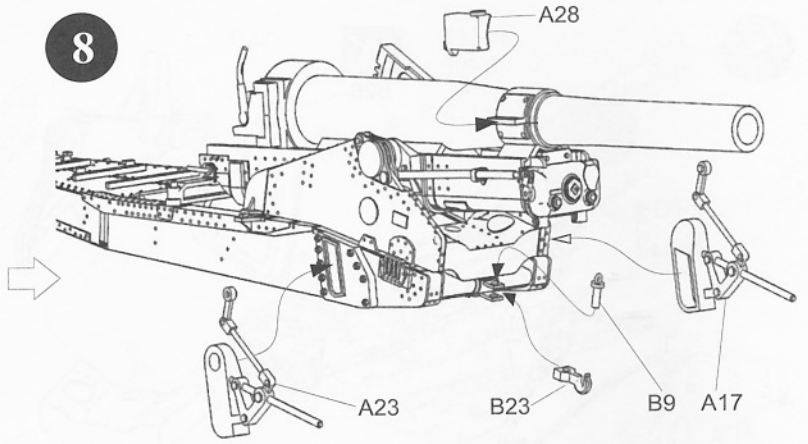
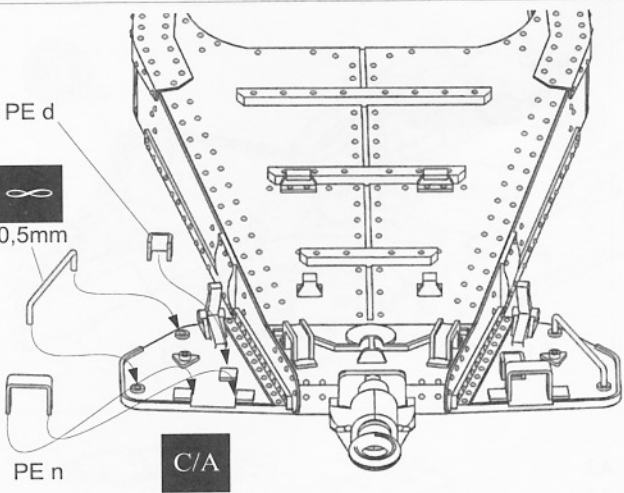

Make two

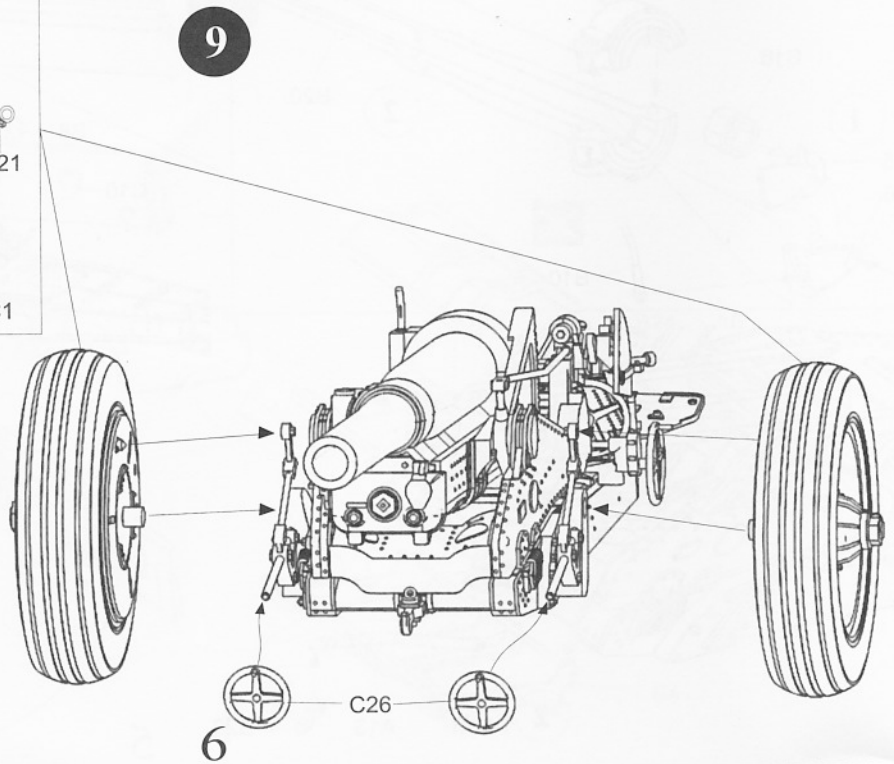
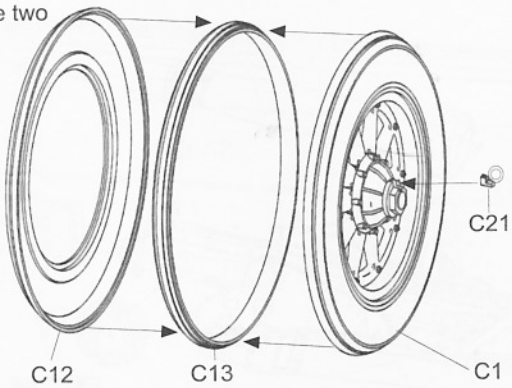

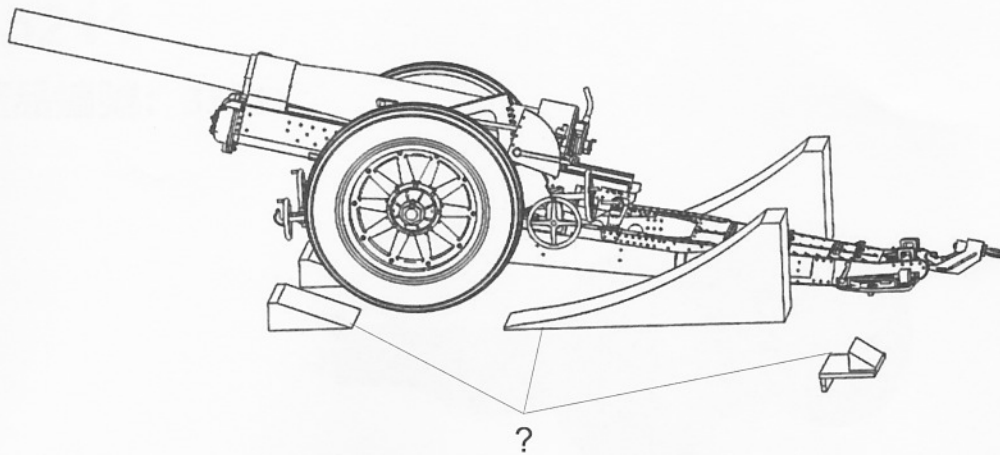

?

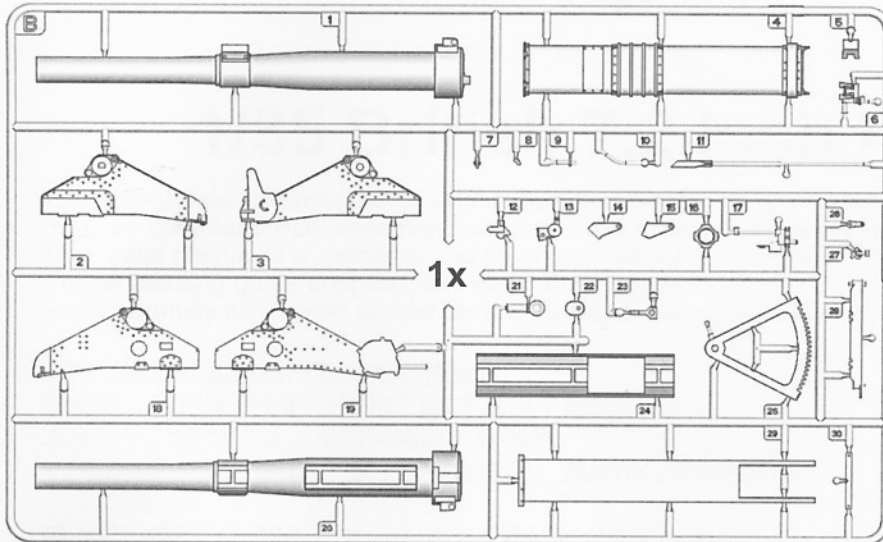

1x

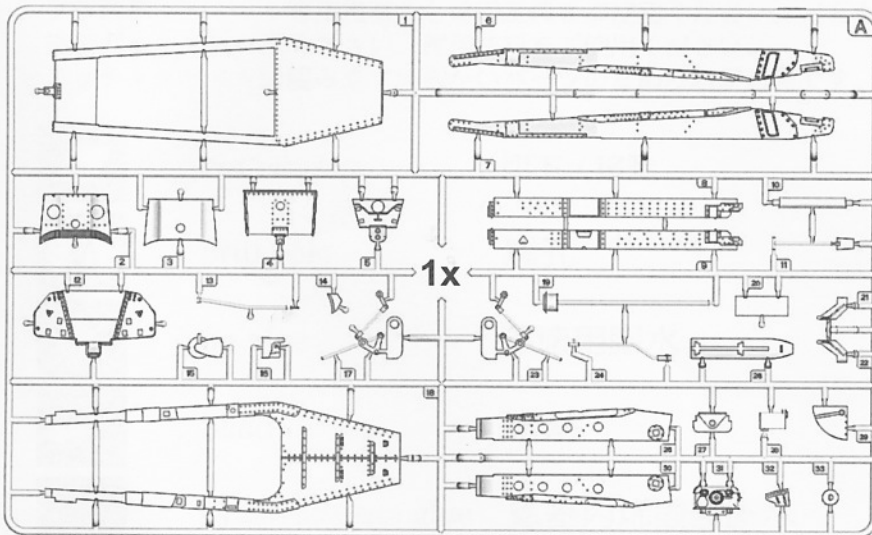

1x

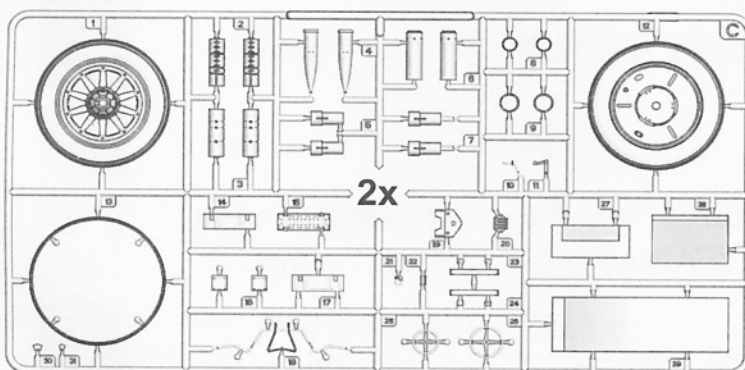

2x

+ 2xPE sheet, wire, decal

# Thunder

MODEL

迅雷模型

www.migjimenez.com



# 7.2 INCH HOWITZER

## Painting and Marking Guide

A.MIG 033 Rubber & Tires

A.MIG 075 Stone Grey

A.MIG 111 SCC 2

51st Heavy Regiment, Royal Artillery,  
France, September 1944

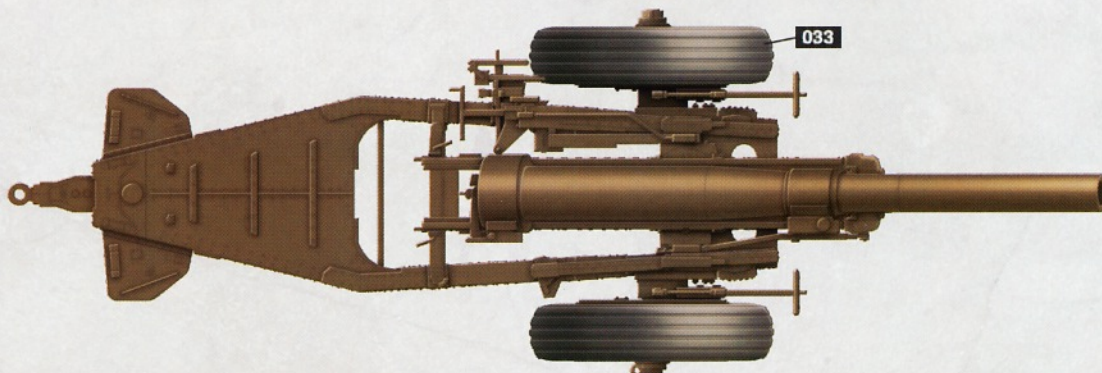
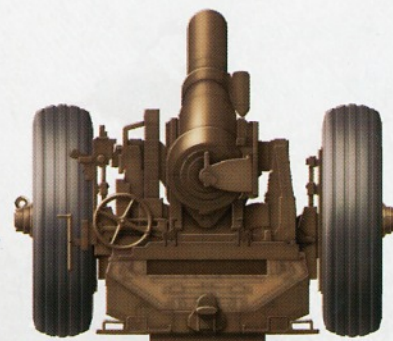
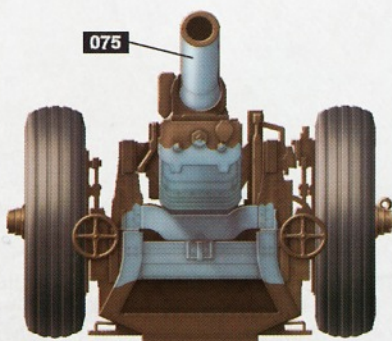
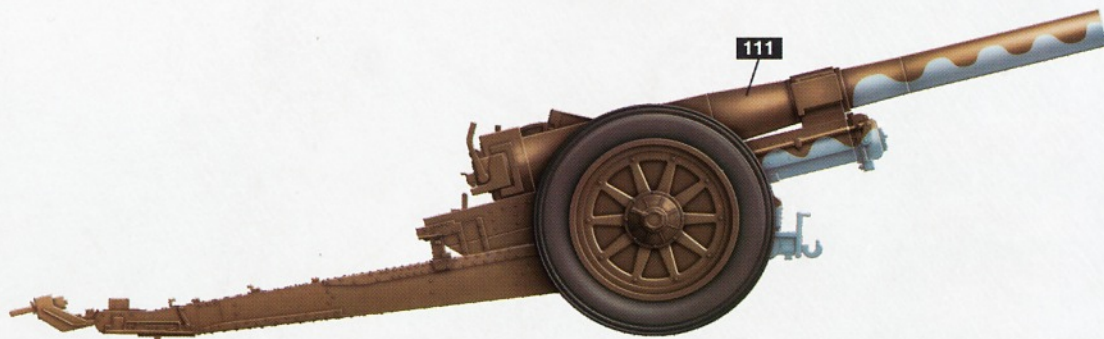
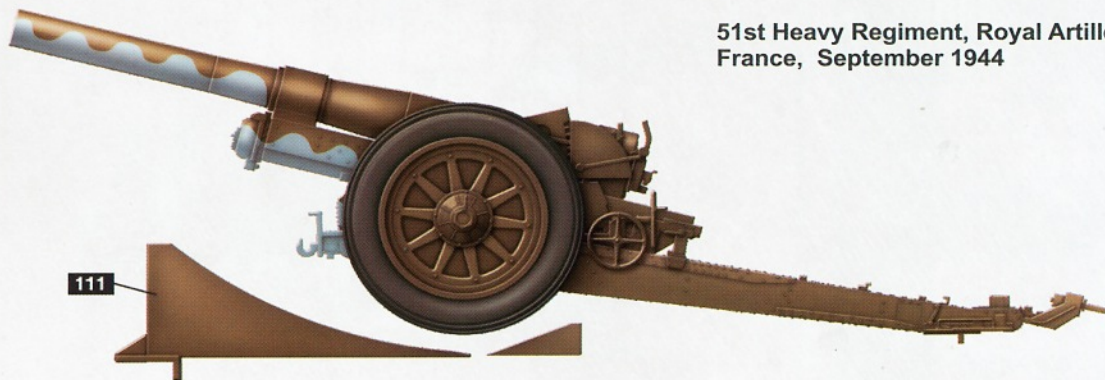

### WEATHERING STEPS WITH AMMO PRODUCTS

**1** GENERAL WASH

A.MIG-1005 Dark Brown Wash for Green Vehicles

**2** FILTER

A.MIG-1507 TAN for Yellow Green

**3** STREAKING

A.MIG-1203 Streaking Grime

**4** DUST

A.MIG-1404 North Africa Dust

**5** MUD

A.MIG-3018 Middle East Dust

A.MIG-1750 Dry Earth

Ref: TM-35211

# Thunder

MODEL

迅雷模型

www.migjimenez.com



# 7.2 INCH HOWITZER

Ref: TM-35211

## Painting and Marking Guide

A.MIG 033 Rubber & Tires

A.MIG 110 SCC 1A

A.MIG 111 SCC 2

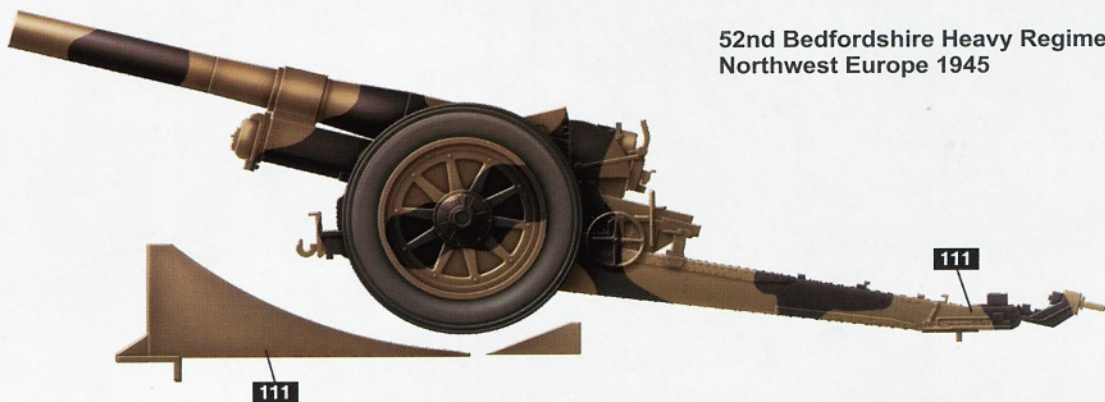

52nd Bedfordshire Heavy Regiment,  
Northwest Europe 1945

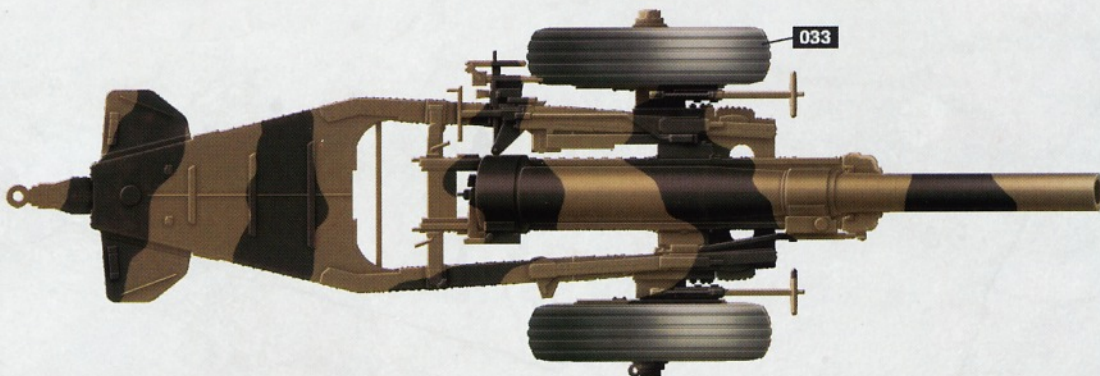
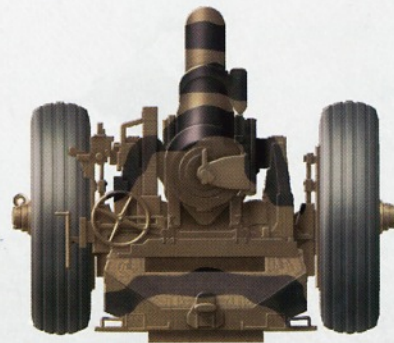
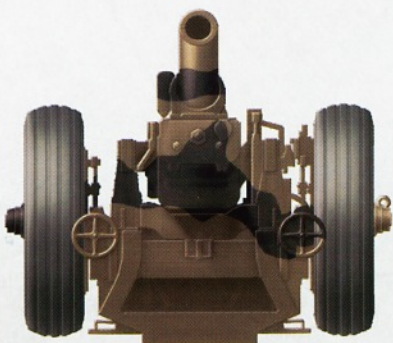
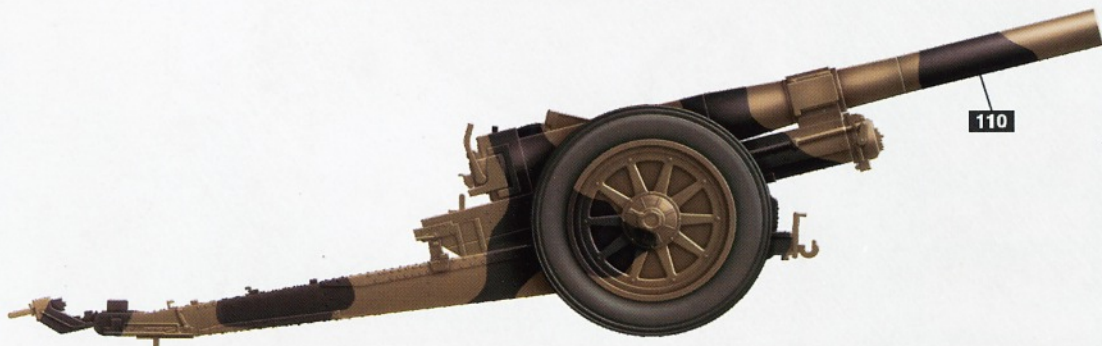

### WEATHERING STEPS WITH AMMO PRODUCTS

**1 GENERAL WASH**

A.MIG-1005 Dark Brown Wash for Green Vehicles

**2 FILTER**

A.MIG-1507 TAN for Yellow Green

**3 STREAKING**

A.MIG-1203 Streaking Grime

**4 DUST**

A.MIG-1404 North Africa Dust

**5 MUD**

A.MIG-3018 Middle East Dust

A.MIG-1750 Dry Earth