

## Volkswagen Typ 825 Pick Up

### NÁVOD / INSTRUCTIONS

#### CZ – HISTORIE

Ferdinand Porsche vyvíjel na konci třicátých let minulého století na přímý popud Adolfa Hitlera vůz pro široké vrstvy obyvatel Německa. Vznikl tak stroj označovaný KdF-Wagen podle hesla Kraft durch Freude – Radost ze síly, pozdější, po válce velmi úspěšný VW Brouk. V roce 1938, s blížícím se válečným konfliktem, byl zahájen vývoj vojenských verzí. Vznikly tak dvě základní větve. Jednu představoval Typ 82E s pohonem zadních kol, druhou pak Typ 877 s pohonem všech kol. V průběhu druhé světové války byly tyto vozy široce užívány Wehrmachtem i dalšími vojenskými či státními složkami Třetí říše. Během války vznikaly další různé přestavby a úpravy, např. přestavba na pohon dřevoplynem apod. Jednou z prvních přestaveb byla varianta Pick Up, označená Typ 825. Úpravou karoserie typu 82 a její montáží na podvozek se zvýšenou průchodivostí vznikl dvojmístný automobil, nabízející velkou otevřenou ložnou plochu. Další podobné vozy postavené na základě Typu 82E byly Typ 83 a 86 Kastenwagen. Tyto verze byly charakteristické skříňovou nástavbou namontovanou na zadní části trupu. Ovšem lišily se vnitřním vybavením podle účelu užití. Vzniklý velký úložný prostor byl u Typu 83 využíván pro přepravu pošty – tyto vozy byly dodány státní poště Reichpost. Typ 86 byl používán jako sanitní.

#### EN – HISTORY

In the late 1930s on Adolf Hitler's direct impulse, Ferdinand Porsche, a German automotive designer was developing a car suitable for wide masses of Nazi Germany. This development gave birth to the so called KdF-Wagen vehicle, named after the Kraft-durch-Freude slogan, literally meaning Strength Through Joy, the car to be better known as the VW Beetle in the post war era. In 1938 as the war was getting closer and closer, the development of military versions began, producing two main branches of the type, the first of which was the Typ 82E with rear wheel drive and the other was the Typ 877 with all four wheels drive. These vehicles were widely used by Third Reich's military and other state sectors too all the way through the war. Many various subversions, conversions of the main type and also various improvements and upgrades arose during the war too, some of them being for instance a wood gas drive conversion and others. One of the early conversions was the Typ 825 Pick Up created using a modified Typ 82 body a chassis with improved passability giving a new vehicle for a crew of two and offering also a large load area. Rather important subversions based on the Typ 82E were also the series of Typ 83 and Typ 86 Kastenwagen vehicles, characterised by a box-shaped wooden superstructure mounted on the rear of the car body. The two Types differed from each other by having a different interior of their superstructures depending on the roles the vehicles were used in. The large internal space of the Typ 83 was mostly used for mail transport with the Reichspost while the Typ 86 saw service as an ambulance car.

# PLASTIC PARTS

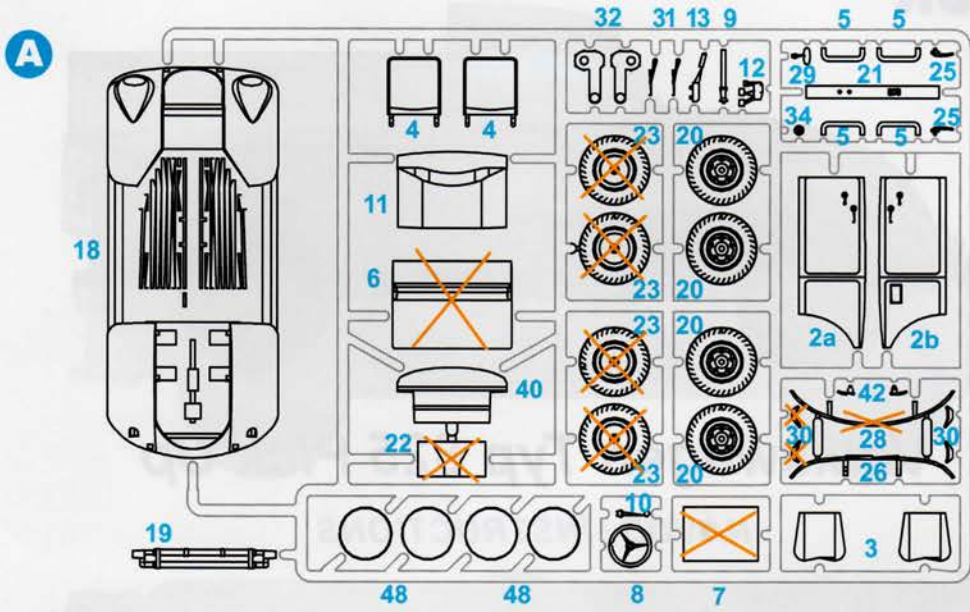

## B

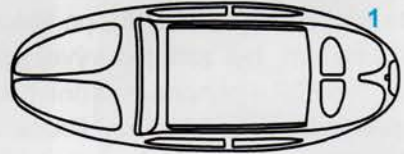
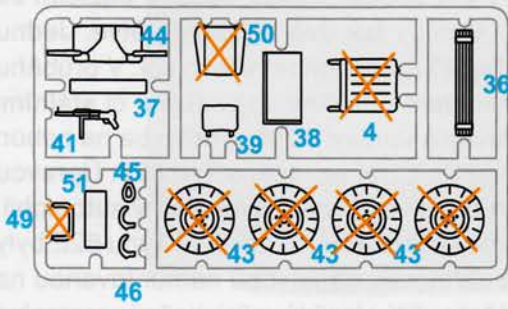

## PHOTO-ETCHED PARTS (PP)



## CLEAR PARTS (CP)

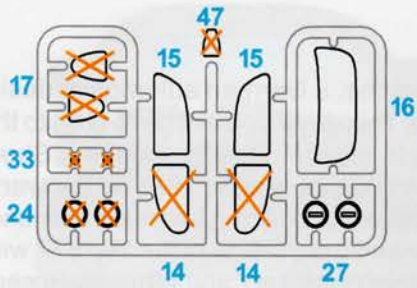

 *Tento díl nepoužít*  
*Do not use this part*



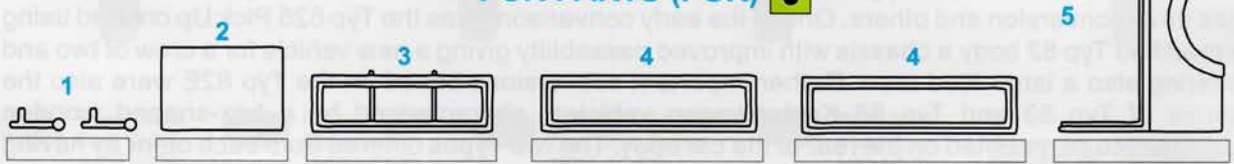



## PUR PARTS (PUR)



## Barvy GUNZE / GUNZE Colour No.

<b>A</b>	Matná černá / Flat Black	H12 / C33	<b>F</b>	Tmavě žlutá / Dark Yellow	H403 / C39
<b>B</b>	Bílá / White	H1 / C1	<b>G</b>	Čokoládově hnědá / Chocolate Brown	H406 / C406
<b>C</b>	Ocelová / Steel	H18 / C28	<b>H</b>	Olivově zelená / Olive Green	H420 / C120
<b>D</b>	Červenohnědá / Red Brown (Leather)	H47 / C41	<b>I</b>	Černá pneu / Tire Black	H77 / C137
<b>E</b>	Polní šedá / Field Gray	H32 / C40	<b>J</b>	Čirá červená / Clear Red	H94 / C138

### SYMBOLS

 MOŽNOST VOLBY OPTIONAL NACH BELIEBEN OPTION	 POUŽÍT KYANOAKRYLÁTOVÉ LEPIDLO INSTANT CYANOACRYLATE GLUE ZYANOAKRYLÁTKLEBER COLLE CYANOACRYLAT	 OHNOUT BEND BIEGEN COURBER	 ZHOŠŤOVAT NOVÉ SCRATCH BUILD FERTIGSTELLEN ACHEVER	 ŘEZAT/VRTAT CUT OFF/DRILL ENTFERNEN DETACHER	 GSI  colours code NATRÍT COLOUR FARBEN PEINDRE
--	--	---	---	---	---

1



1

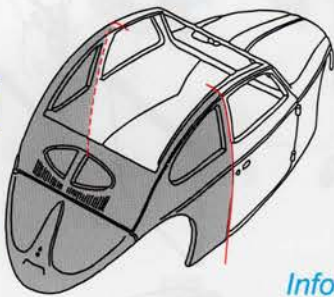

InfoVIEW

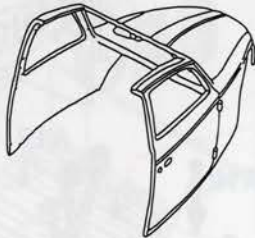

A2b

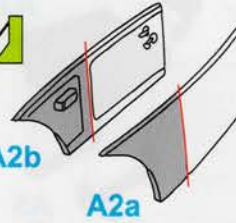

A2a

InfoVIEW

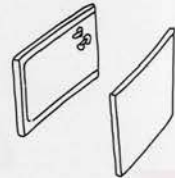

A18

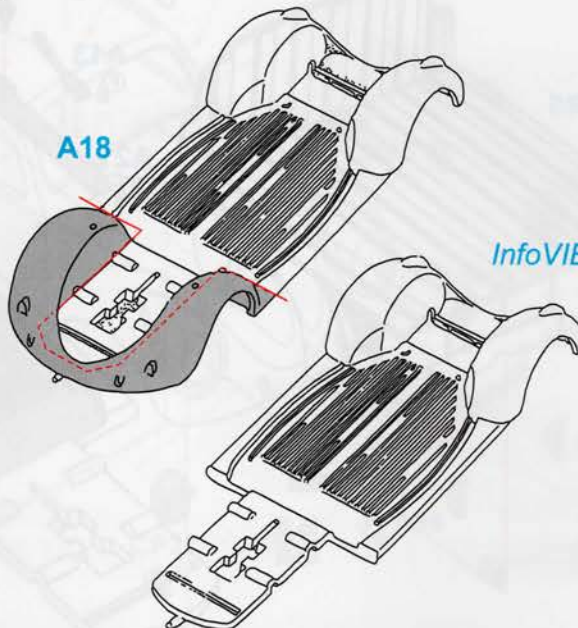

InfoVIEW

2

PLASTIC PARTS

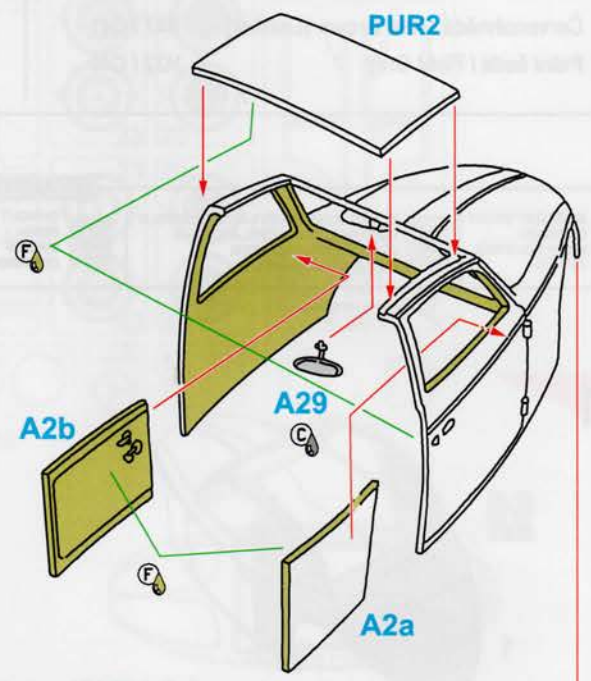
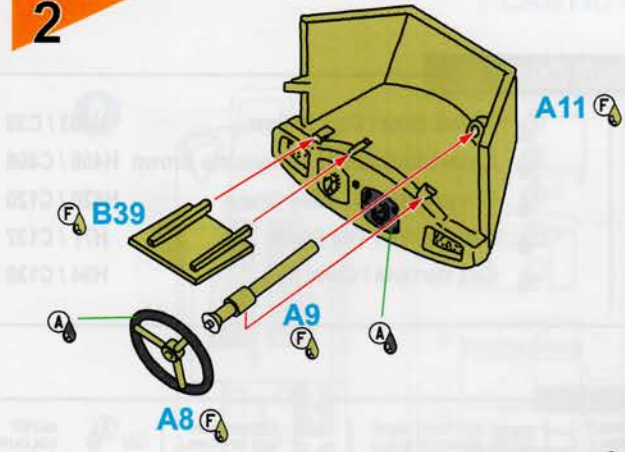

3

2x

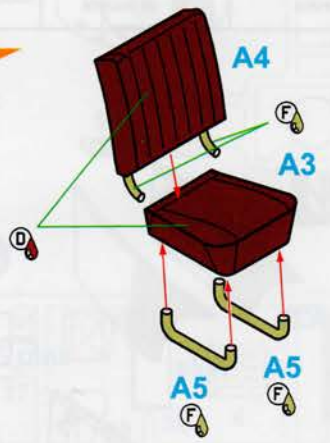

STEP 3

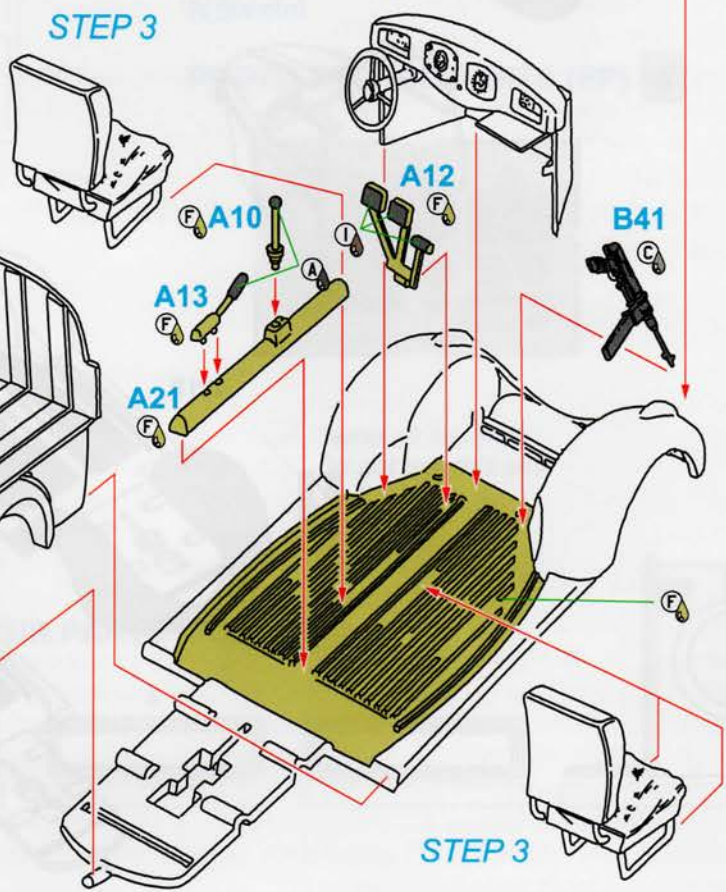

4

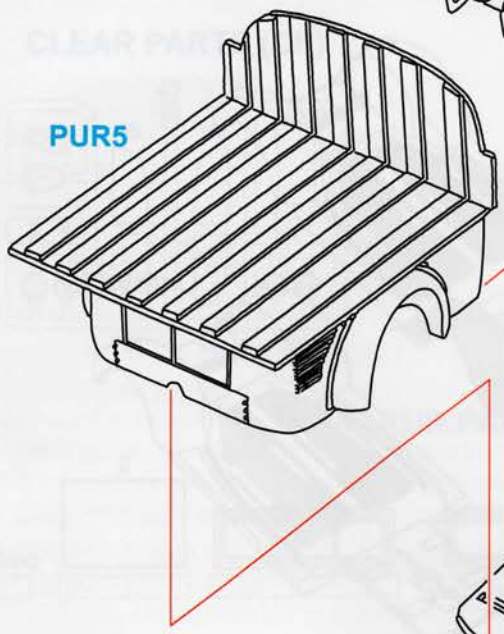

5

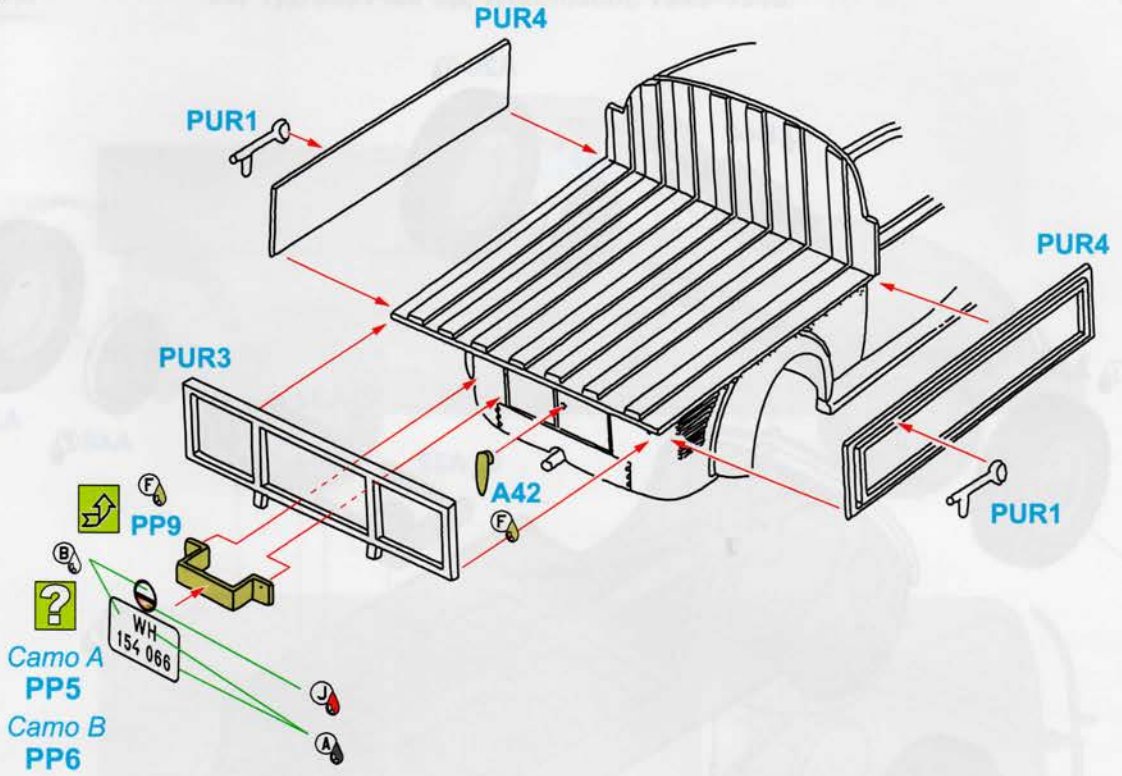

6

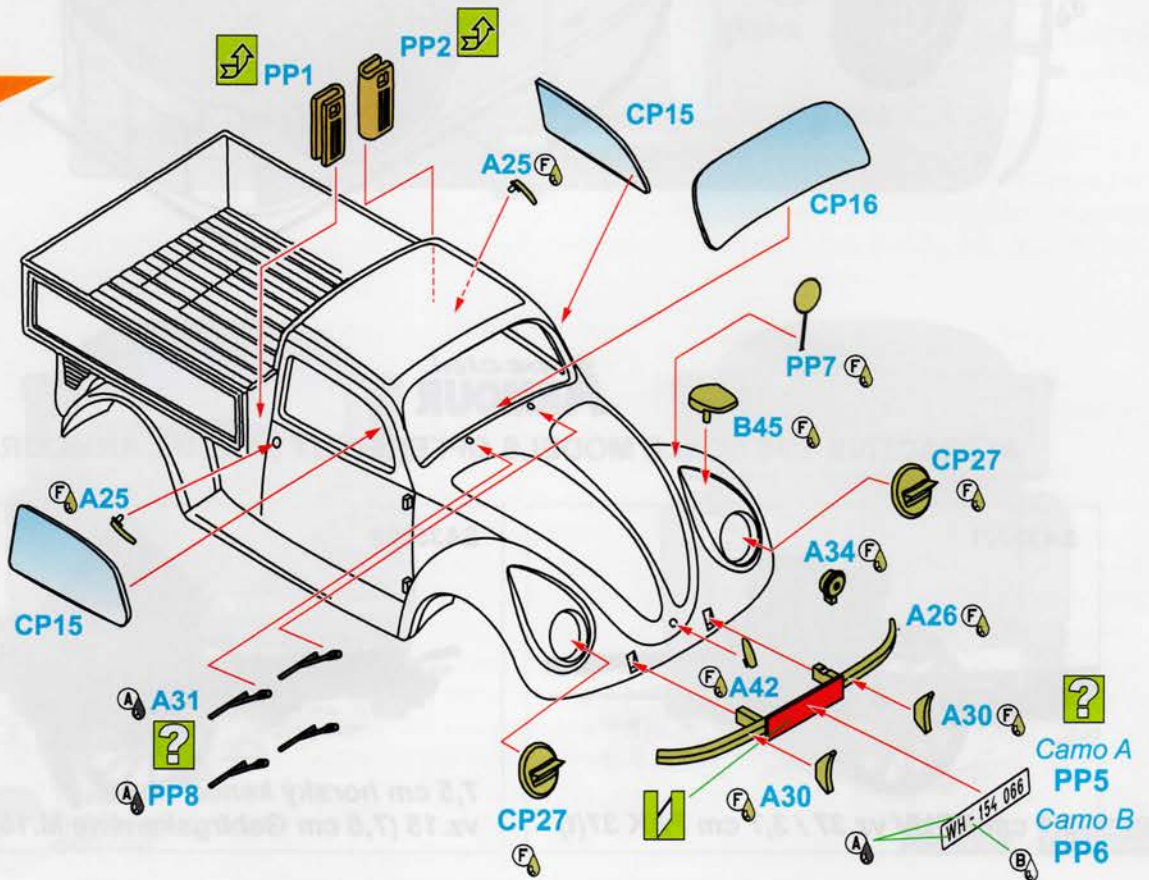

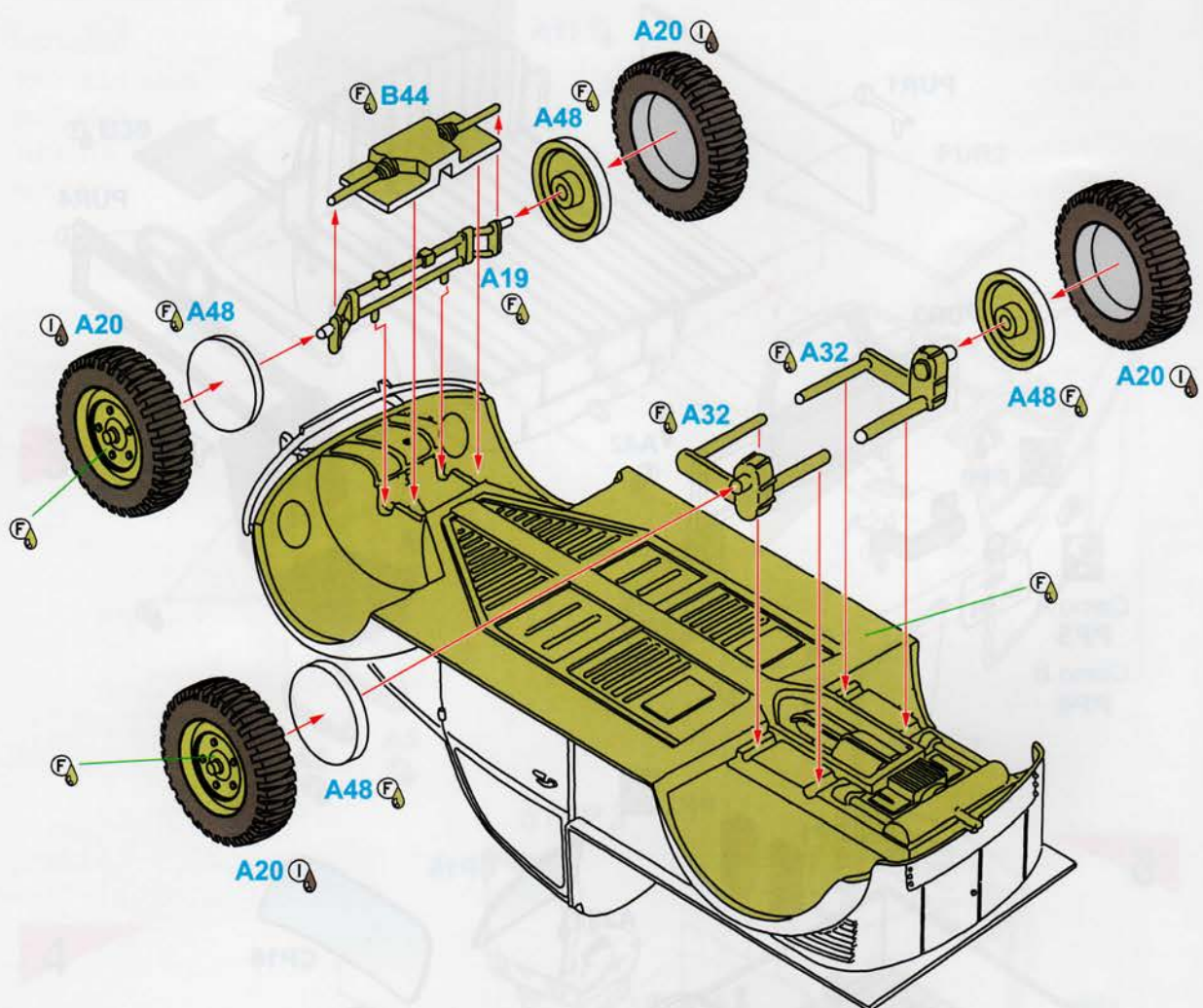

**Special**  
**ARMOUR**

ATTRACTIVE 1/35 SCALE MODELS OFFERED BY SPECIAL ARMOUR



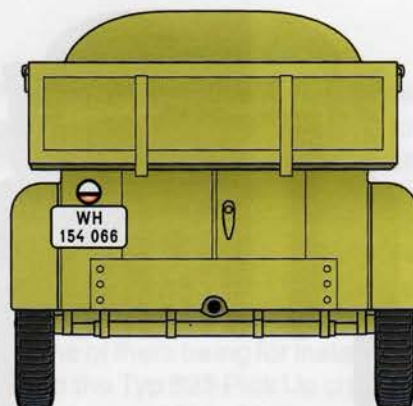
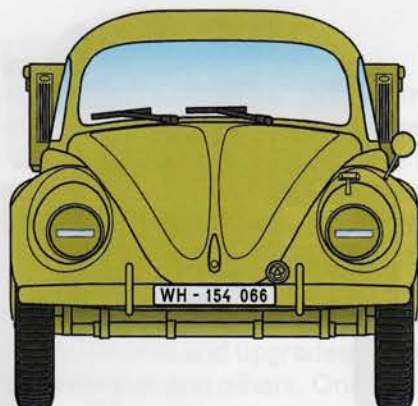
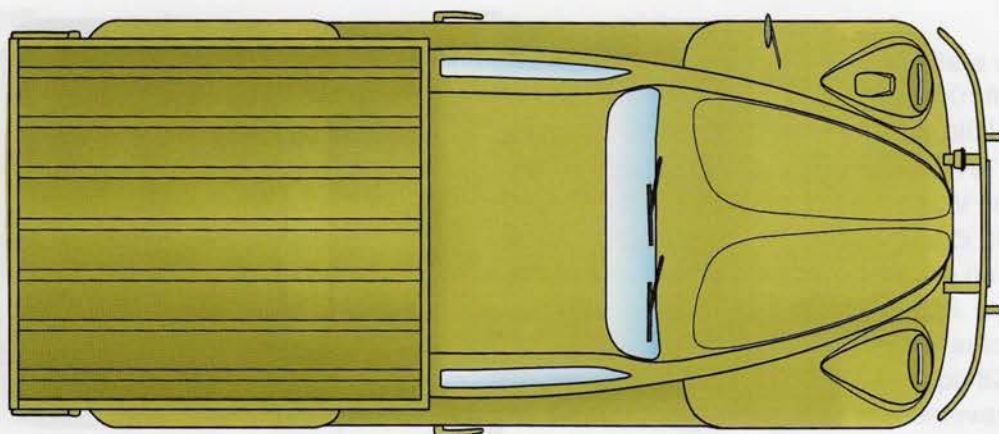
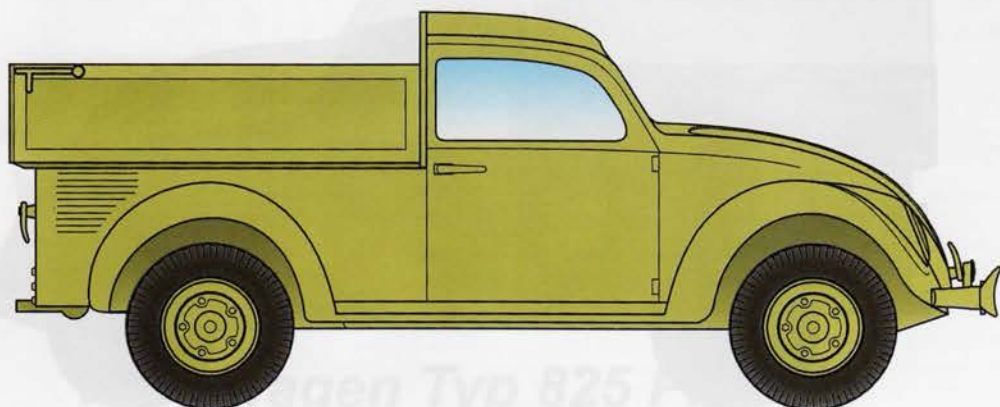

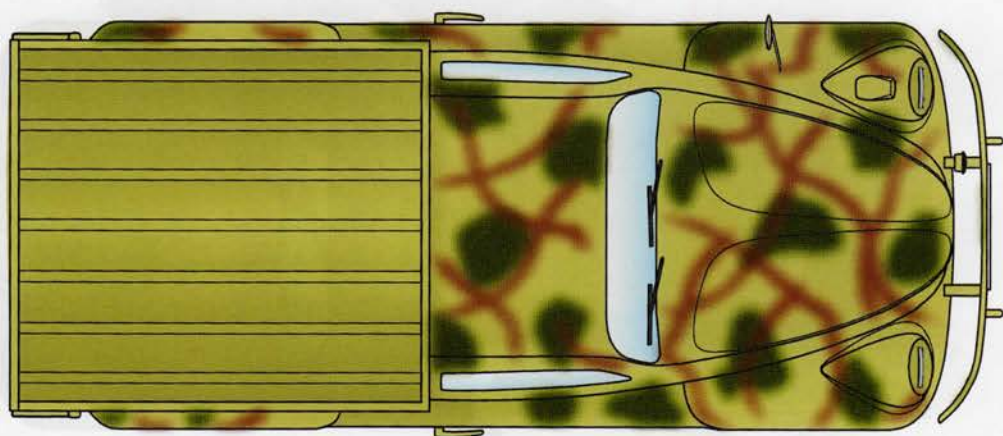
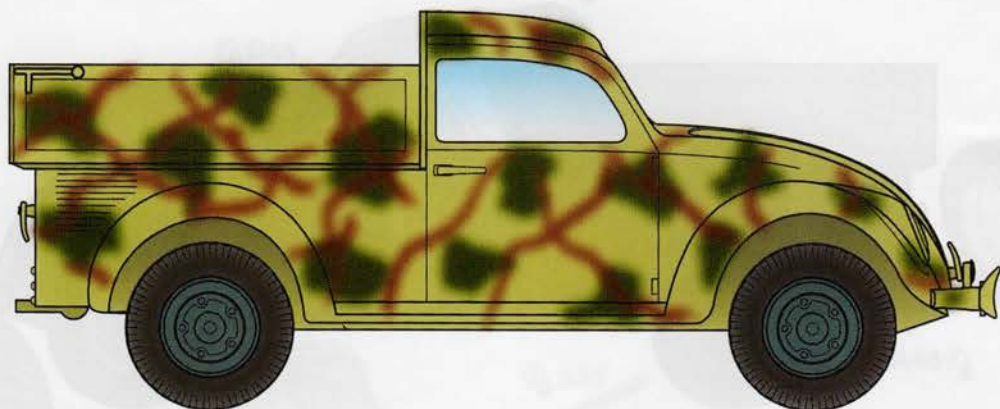

 Tmavě žlutá  
Dark Yellow  
H403 / C39



 Tmavě žlutá  
Dark Yellow  
H403 / C39

 Olivově zelená  
Olive Green  
H420 / C120

 Čokoládově hnědá  
Chocolate Brown  
H406 / C406

 Polní šedá  
Field Gray  
H32 / C40

Special  
**ARMOUR**

**GUNZE**  
SANGYO