

# Pz.Kpfw.VI Ausf.E Tiger I late



## Dor dem Zusammenbau lesen!

DW35028

**組立ての注意**

- ・接着剤や塗料は火の近くで使わないでください。使う時はときどき窓を開けて換気に気をつけましょう。
- ・部品をランナーから切り離す時は模型用ハサミ等を使い、余分な部分はカッターやヤスリ等で仕上げてください。
- ・組立図のサインマークは下の説明をごらんください。

**《注意》**

- ・勿於近火處使用膠水或油漆・並打開窗戶保持空氣流通。
- ・自膠架中取出部件時・應用模型專用剪・並用界刀或小鏟除去多餘的膠料。
- ・各圖型的含意可參考本欄以下的說明。

**ZUR BEACHTUNG**

- ・Kleber und Farbe nicht nahe von offenem Feuer verwenden und das Fenster von Zeit zu Zeit zur Belüftung öffnen.
- ・Zum Abschneiden der Teile vom Verbundstück eine Modellierschere verwenden und die überstehenden Plastikteile mit einem Messer oder einer Feile beseitigen.
- ・Die Bedeutung der Symbols finden Sie unten in dieser Spalte.

**CAUTION**

- ・When you use glue or paint, do not use near a naked flame, and use in a well-ventilated room.
- ・When you take parts off the runner frame, use modeling scissors and trim excess plastic with a cutter or a file.
- ・See below for the meaning of symbols.

**ATTENTION**

- ・Ne pas utiliser de colle ou de peinture a proximite d'une flamme nue, et aerier la piece de temps en temps.
- ・Pour retirer les pieces hors du cadre, utiliser des ciseaux speciaux pour maquette le plastique en excès avec un cutter ou une lime.
- ・Voir la fin de cette colonne pour la signification des symboles

**ATTENZIONE**

- ・Non usare colla a vernice vicino a fiamme esposte. e aprire le finestre di tanto in tanto per cambiare l'aria.
- ・Quando si staccano parti del carrello. usare forbici da modellismo e eliminare la plastica in eccesso con un coltello o una lima.
- ・Vedere in fondo a questa colonna per il significato dei simboli.

**x2** 2つつけてください  
MAKE 2PCS  
2 TEILE FERTIGEN  
EFFECTUER 2 PIECES  
FARE DUE PEZZI  
TEE 2 KPL  
GOR 2 ST  
製作二組

切り取ってください  
REMOVE  
ENTFERNEN  
RETIRER  
SEPARARE  
POISTA  
AVLAGSNA  
切去

接着しないでください  
DO NOT CEMENT  
NICHT KLEBEN  
NE PAS COLLER  
NON INCOLLARE  
EILIMAA  
LIMMAEJ  
不用黏合

ステッカーを貼ってください  
APPLY DECAL  
HIER ABZIEHBILD  
APPLIQUER DECALCOMANIE  
APPLICARE DECALCOMANIE  
ASETA SIIRTOKUVÄ  
APPLICERA DECALEN  
貼上水印紙

穴を埋めてください  
FILL HOLE  
SCHLIESSEN  
BOUCHER LE TROU  
FORD PIENO  
TAYTÄ REIKA  
FYLL HÄLET  
把孔填平

接着剤が乾くまで2-3分待ちます。  
PLEASE WAIT FOR A FEW MINUTES UNTIL DRY  
ENIGE MINUTEN WARTEN BIS DER KLEBSTOFF GETROCKNET IST  
ASPETARE ALCUN MINUTI FINCHE LA COLLA SI E ASCUGARA  
VEUILLEZ PATIENTER QUELQUES JUSQU'AU SECHAGE  
YÄNTÄ NÄGRÄ MINUTTI TÄLLS TORR  
OODTA MÄUTÄMÄ MINUUTTI KUUNNES KUIVUNUT  
稍候數分鐘 直至接著劑乾固

注意してください  
BE CAREFUL  
HIER VORSICHT  
FAIRE ATTENTION  
USARE ATTENZIONE  
VAROVÄSTI  
FORIKTIGT  
小心留意

穴をめてください  
OPEN HOLE  
ÖFFNEN  
FAIRE UN TROU  
FORO APERTO  
AVÄA REIKA  
ÖPPNÄ HÄLET  
鑽孔

接着してください  
CEMENT TOGETHER  
ZUSAMMENKLEBEN  
COLLER ENSEMBLE  
INCOLLARE INSIEME  
LIMAA YHTEEN  
LIMMA IHOP  
用膠黏合

折り曲げてください  
BEND  
BITTE BIEGEN  
PLIER S'IL VOUS PLAÏT  
PIEGARE  
TAITA  
BOCKA  
屈曲

どちらかを選んでください  
OPTIONAL  
NACH BELIEBEN  
FACULTATIF  
FACOLTATIVO  
VALINNANVARAINEN  
VALBAR  
可以選擇採用

瞬間接着剤(金属用)  
INSTANT GLUE FOR METAL  
METALLKIEBER  
COLLA A METAL INSTANTANEE  
VALINNANVARAINEN  
PIKALIMAA METALLIOSIA VARTEN  
SNÄBELIM FOR METALLDELAR  
金屬用速乾膠

	COLOR	RAL	Tamiya	Mr Hobby H-Series	AMMO of MIG	Vallejo	Humbrol	Mission Models
A	Black	9011	XF1	H12	0046	71.057	33	MMP-047
B	Cremewhite	9001	XF55	H21	0017	71.270	41	MMP-082
C	Dunkelgelb	7028	XF60	H403	0902	71.025	83	MMP-011
D	Schokobraun	8017	XF64	H406	0015	71.041	160	MMP-012
E	Olivgrün	6003	XF58	H405	0001	71.092	86	MMP-009
F	White	9010	XF2	H11	0050	71.001	34	MMP-001
G	Leather		XF10	H463	0133	71.105	62	MMP-002
H	Gun Metal		X10	H28	0045	71.072	53	MMM-001
I	Rust		XF9 + XF10 (50/50)	H453	0040	71.129	113	MMW-005
J	Wood		XF55	H455	0036	71.244	94	MMP-123
K	Dark Tracks		XF56 + XF9 (80/20)	H84	0035	71.039	173	-
L	(Transparent) Black Blue		X23	H93	0099	70.938	222	MMP-168

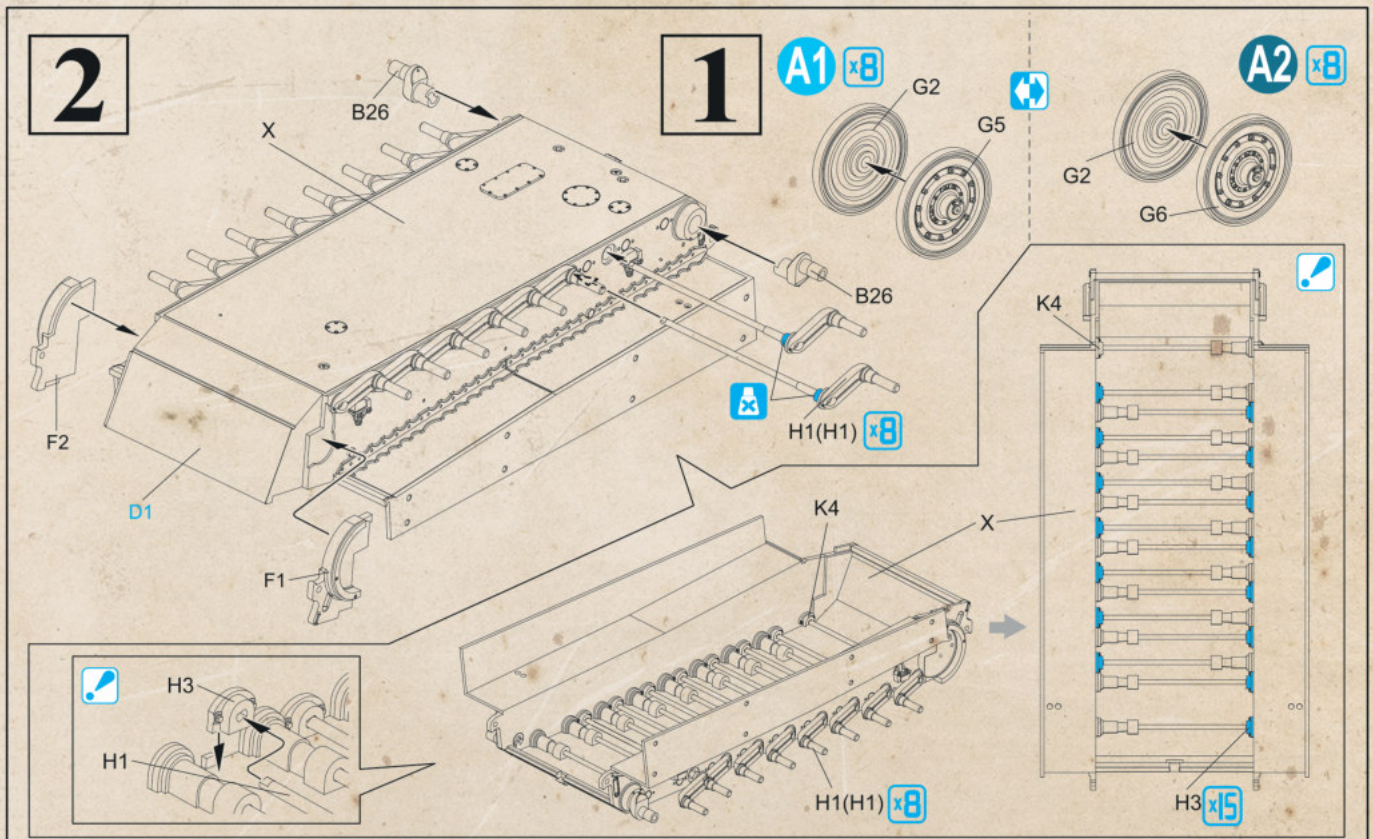
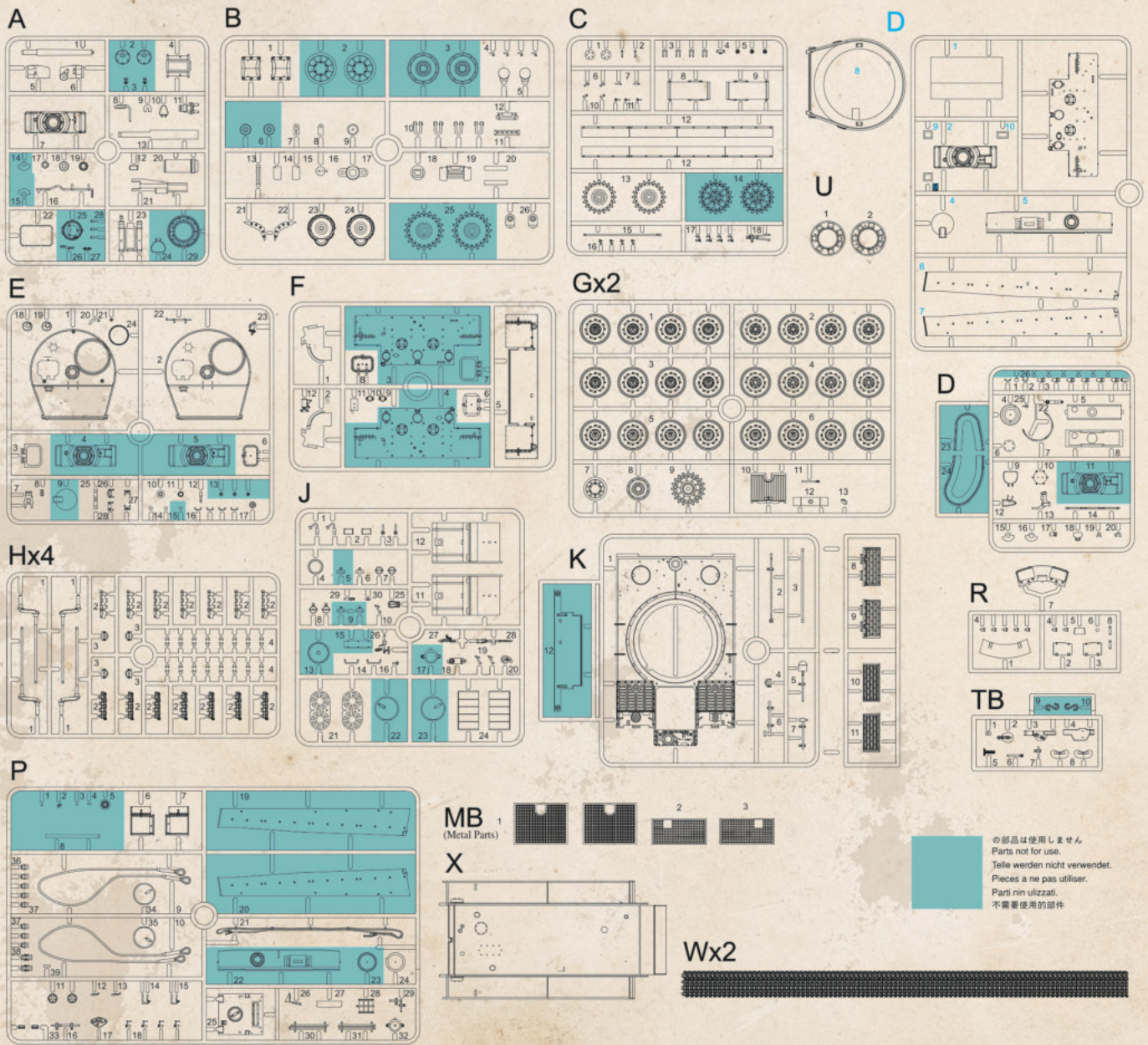

# 3

A1 A2

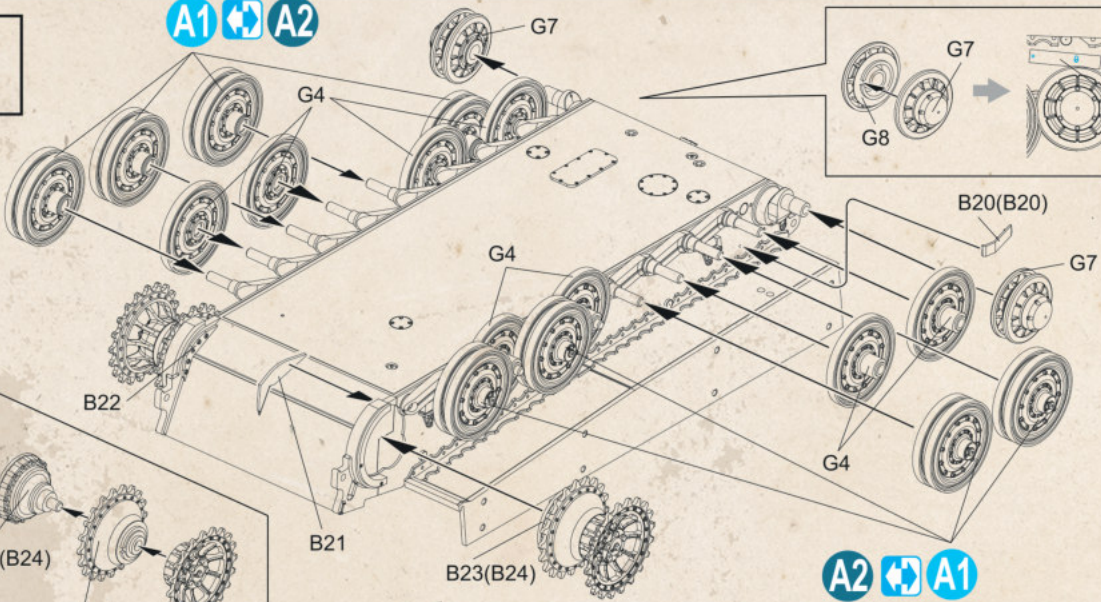

A2 A1



# 4

G3 G1

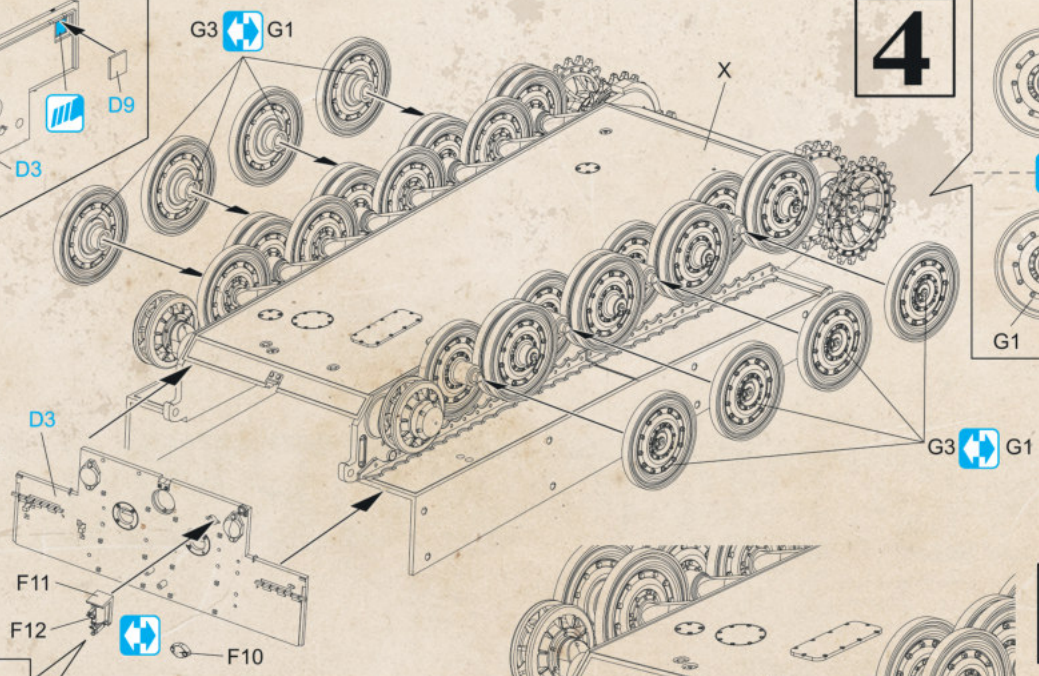

G3

G1

G3 G1

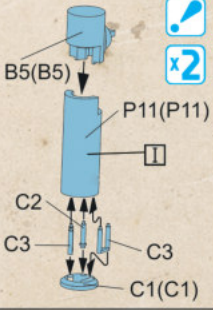
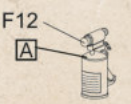

# 5

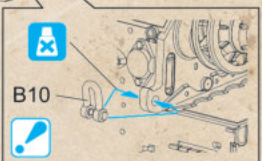
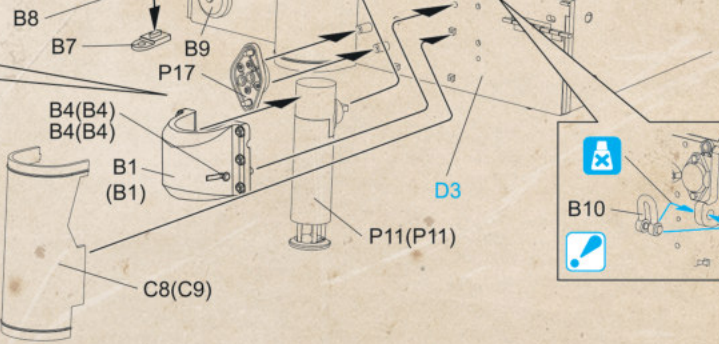

# 6

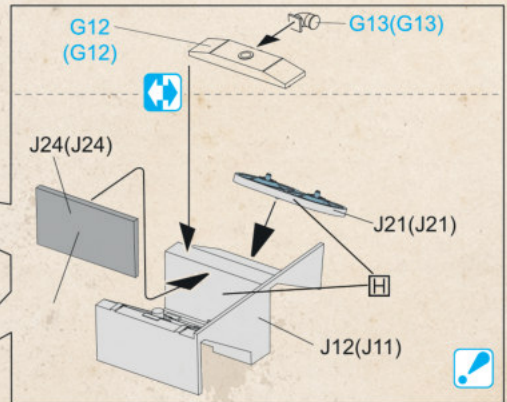
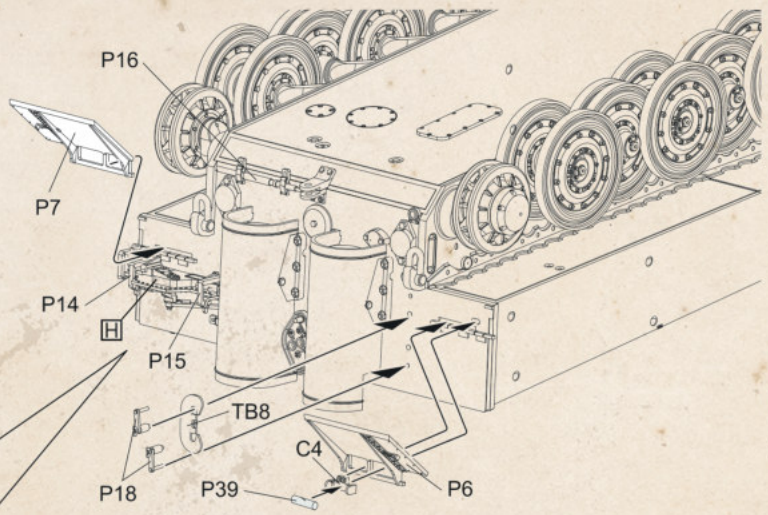
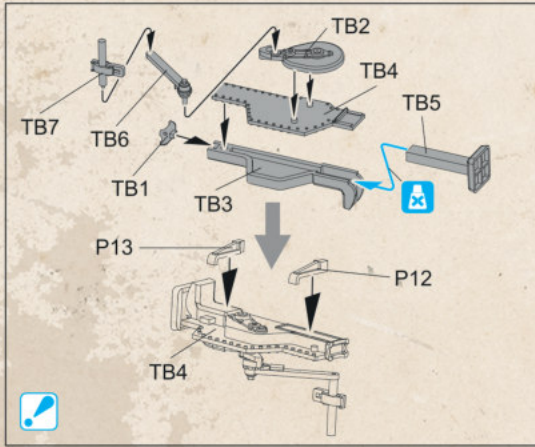

# 7

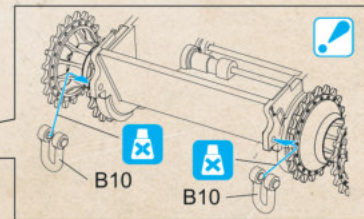
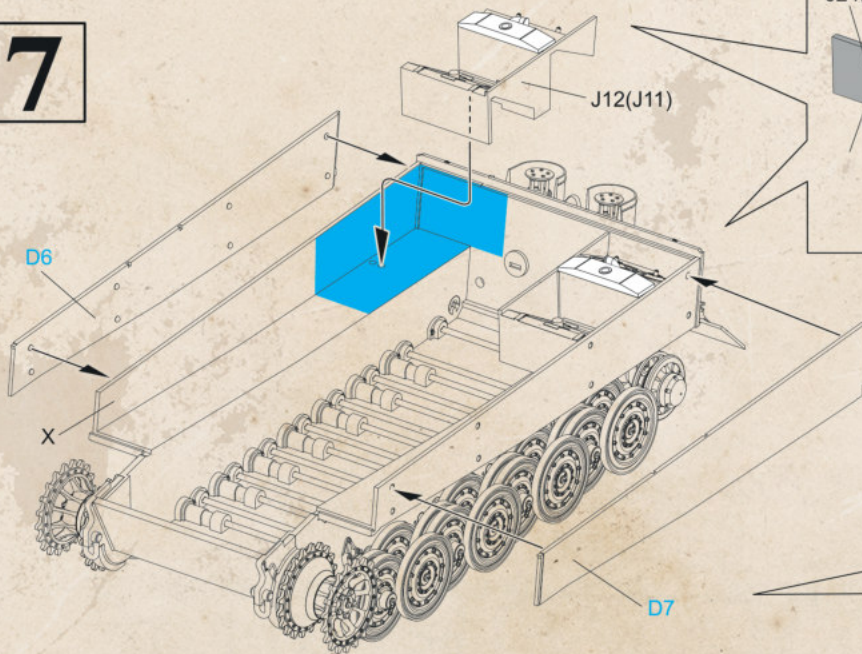

# 8

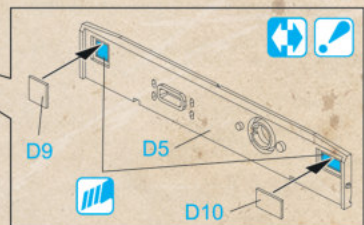
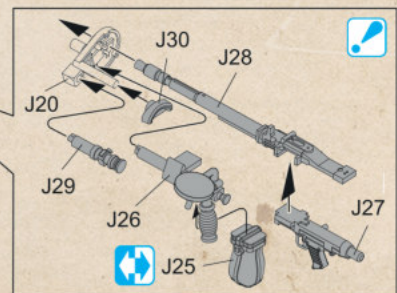
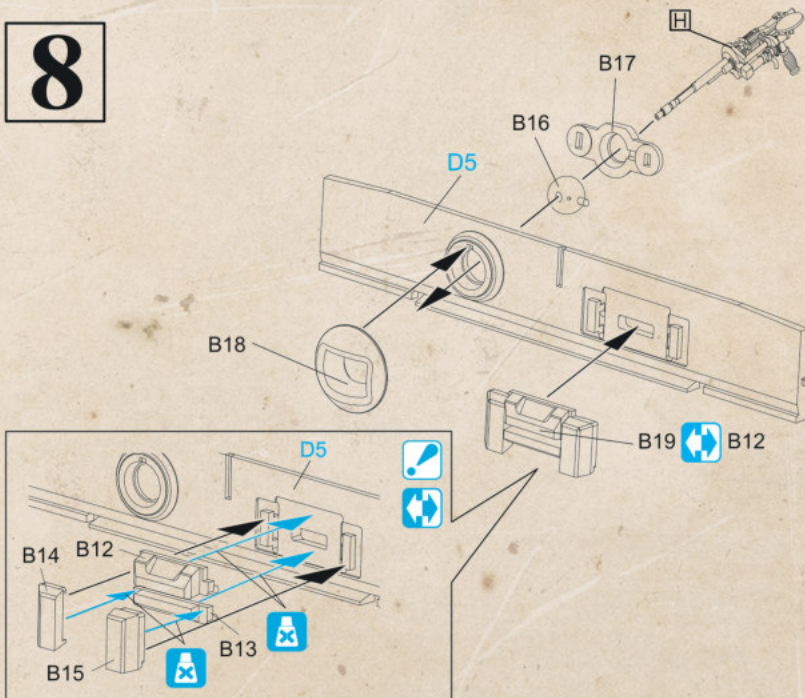

9

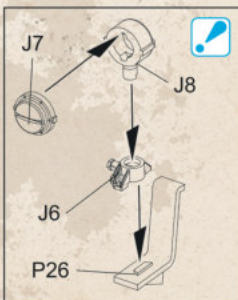
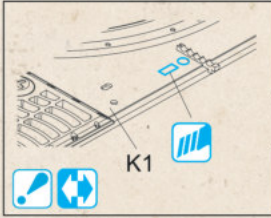

D5

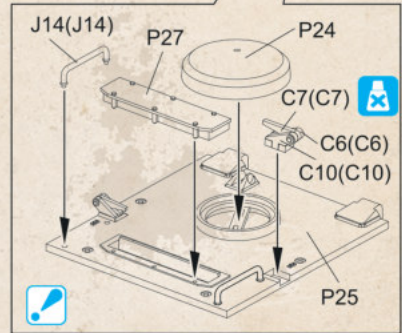
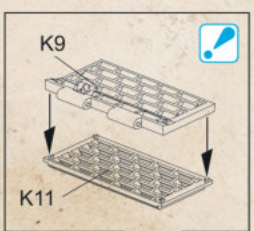
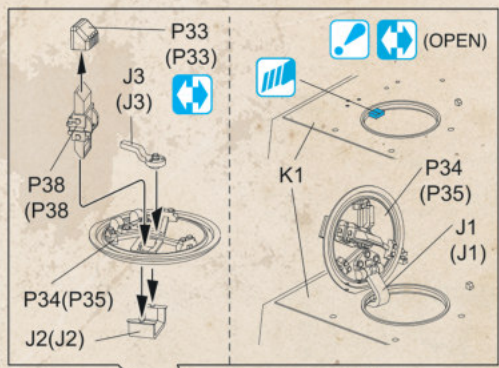

(OPEN/CLOSE)

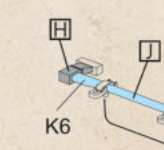

10

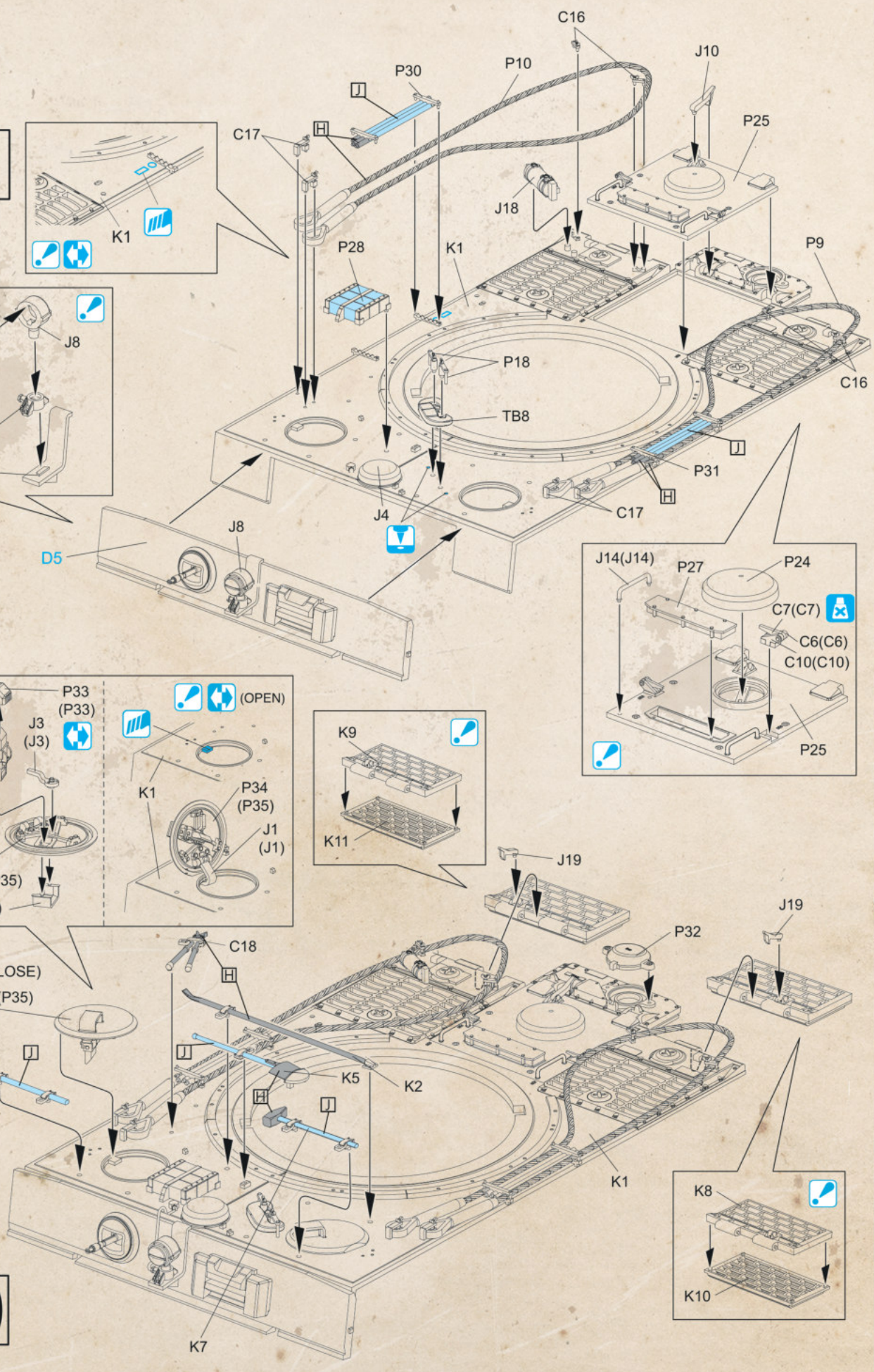
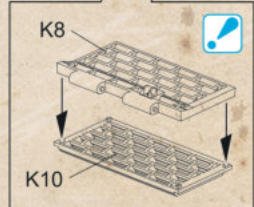

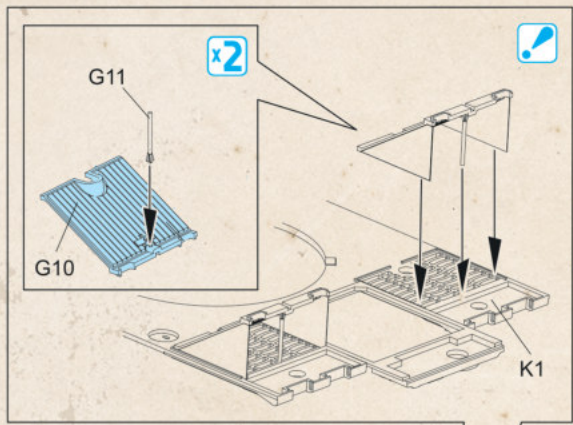
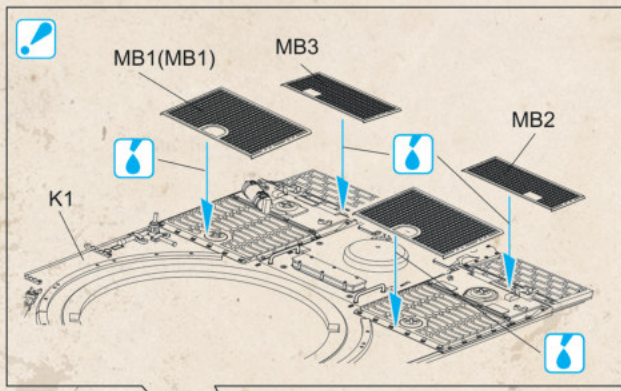

**11**

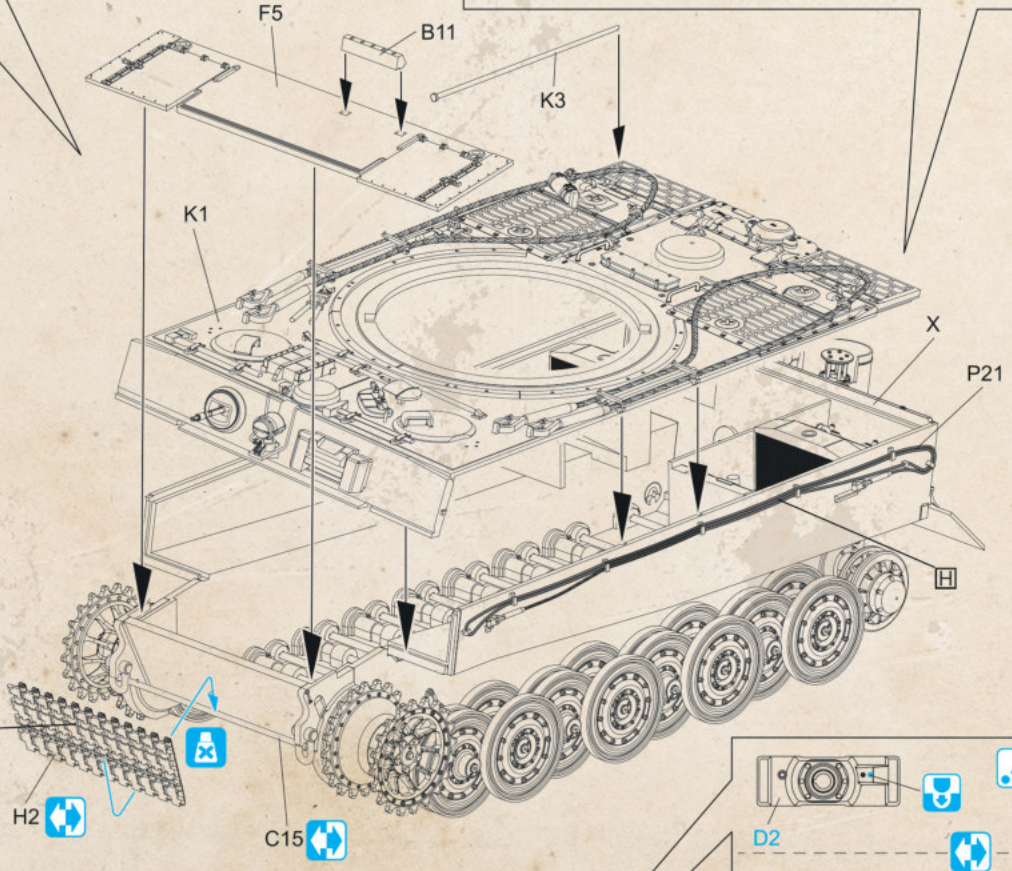

**12**

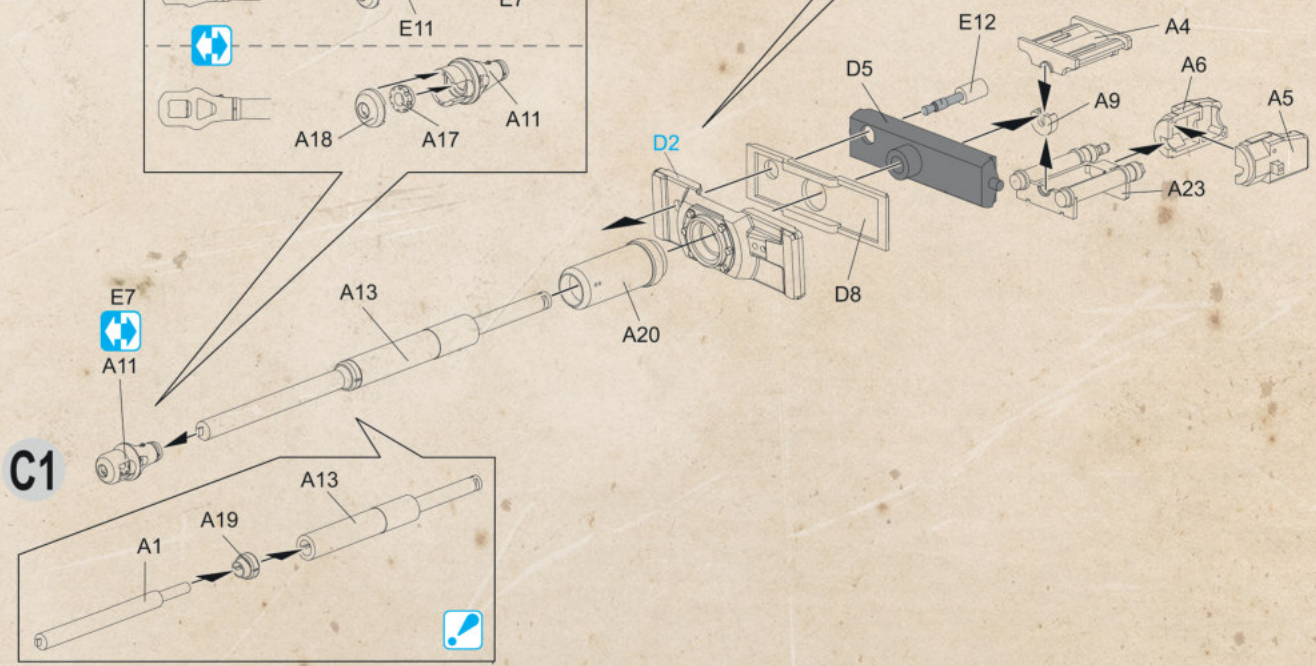
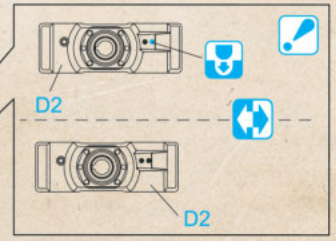
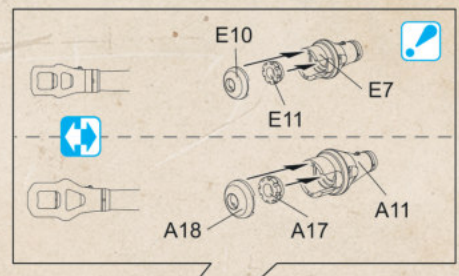

**C1**

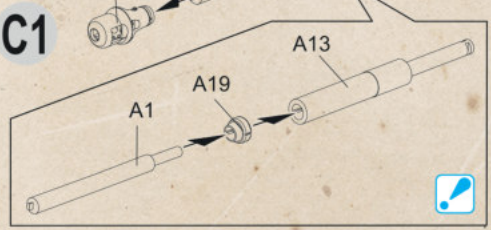

13

14

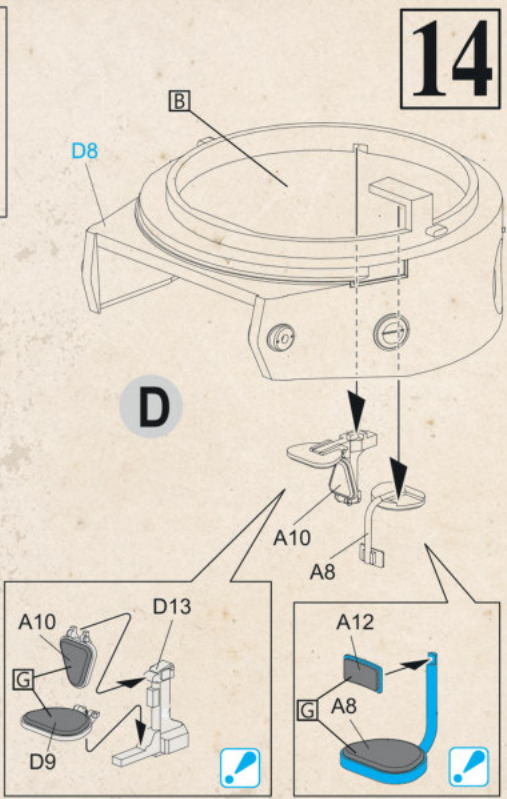
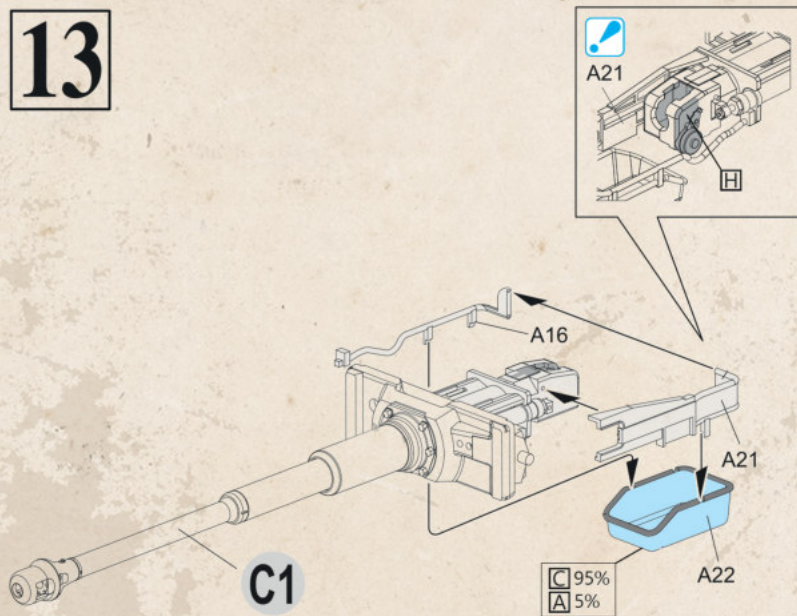

15

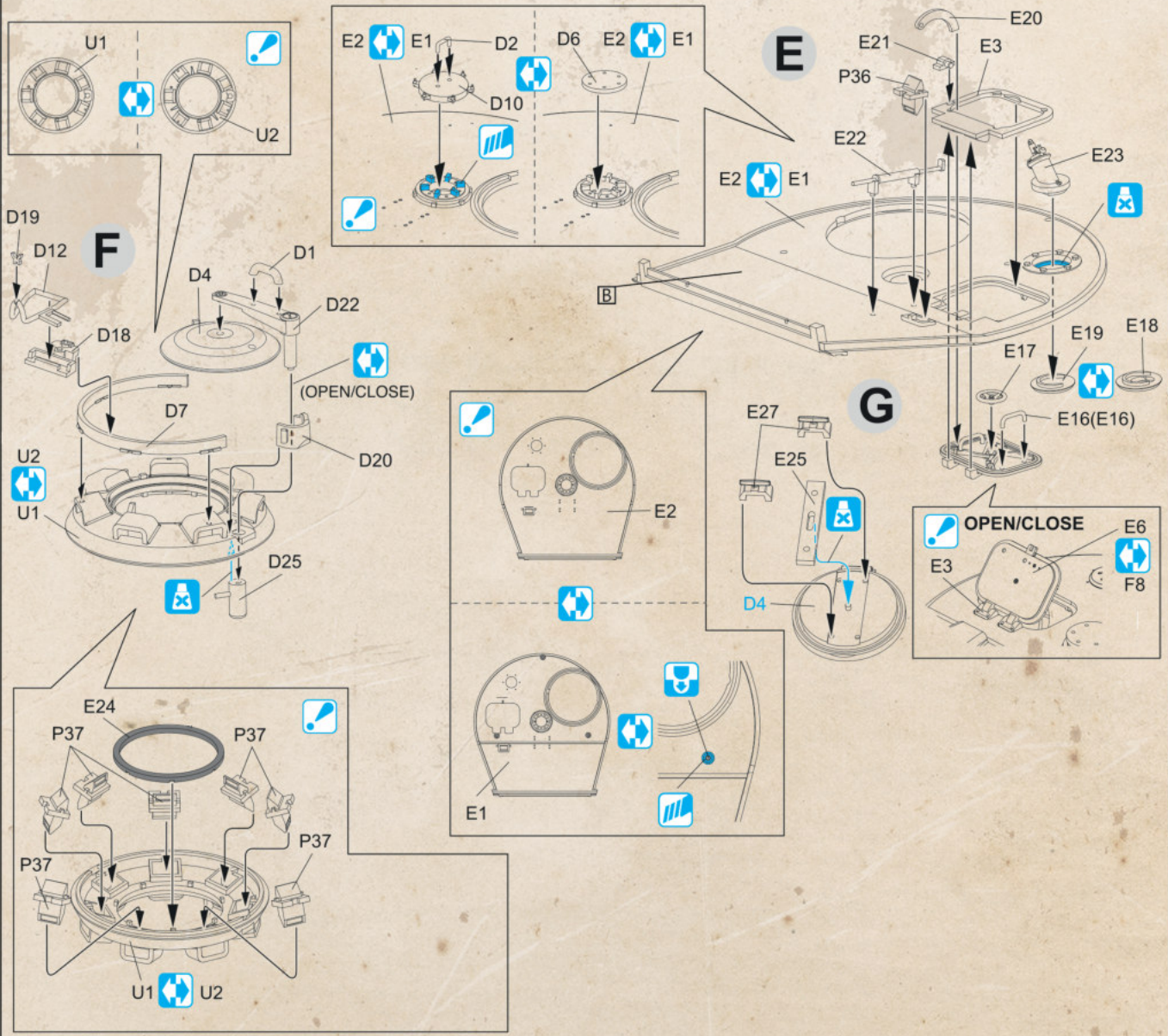

16

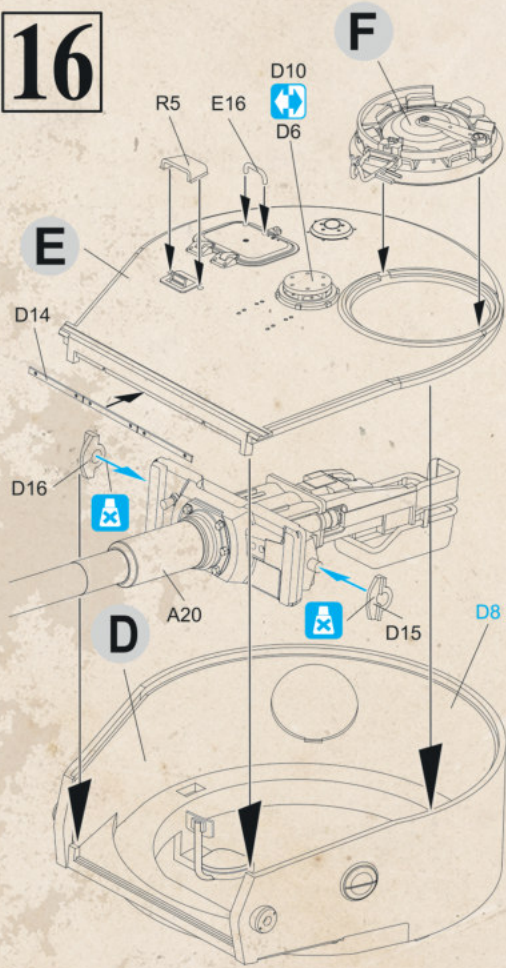

17

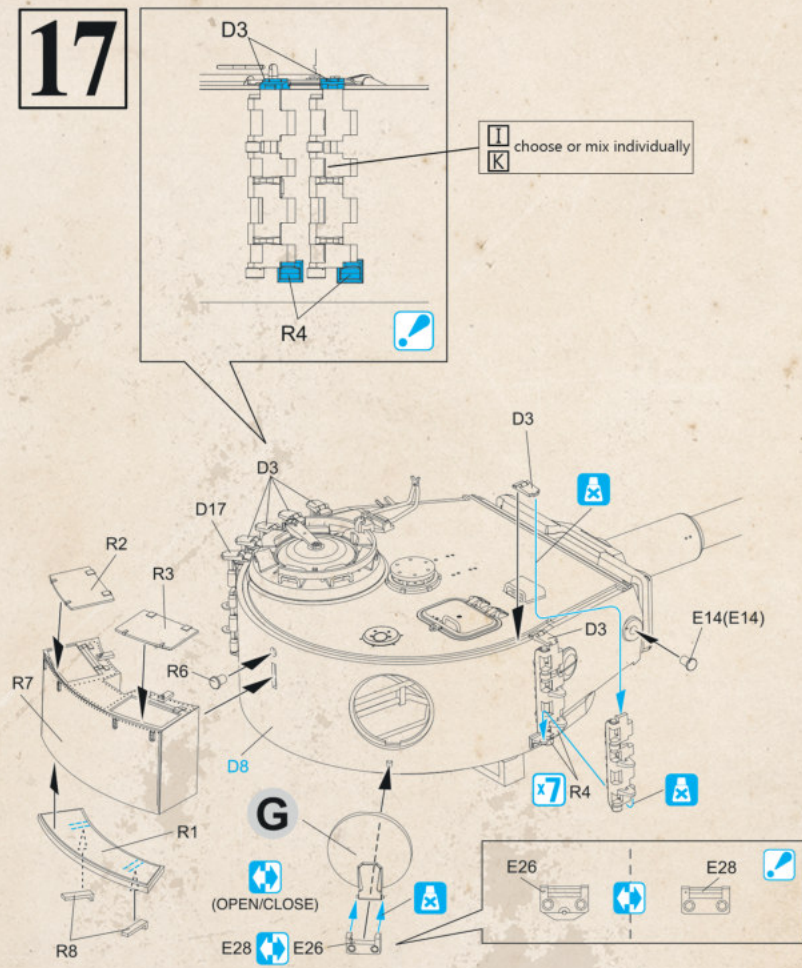

18

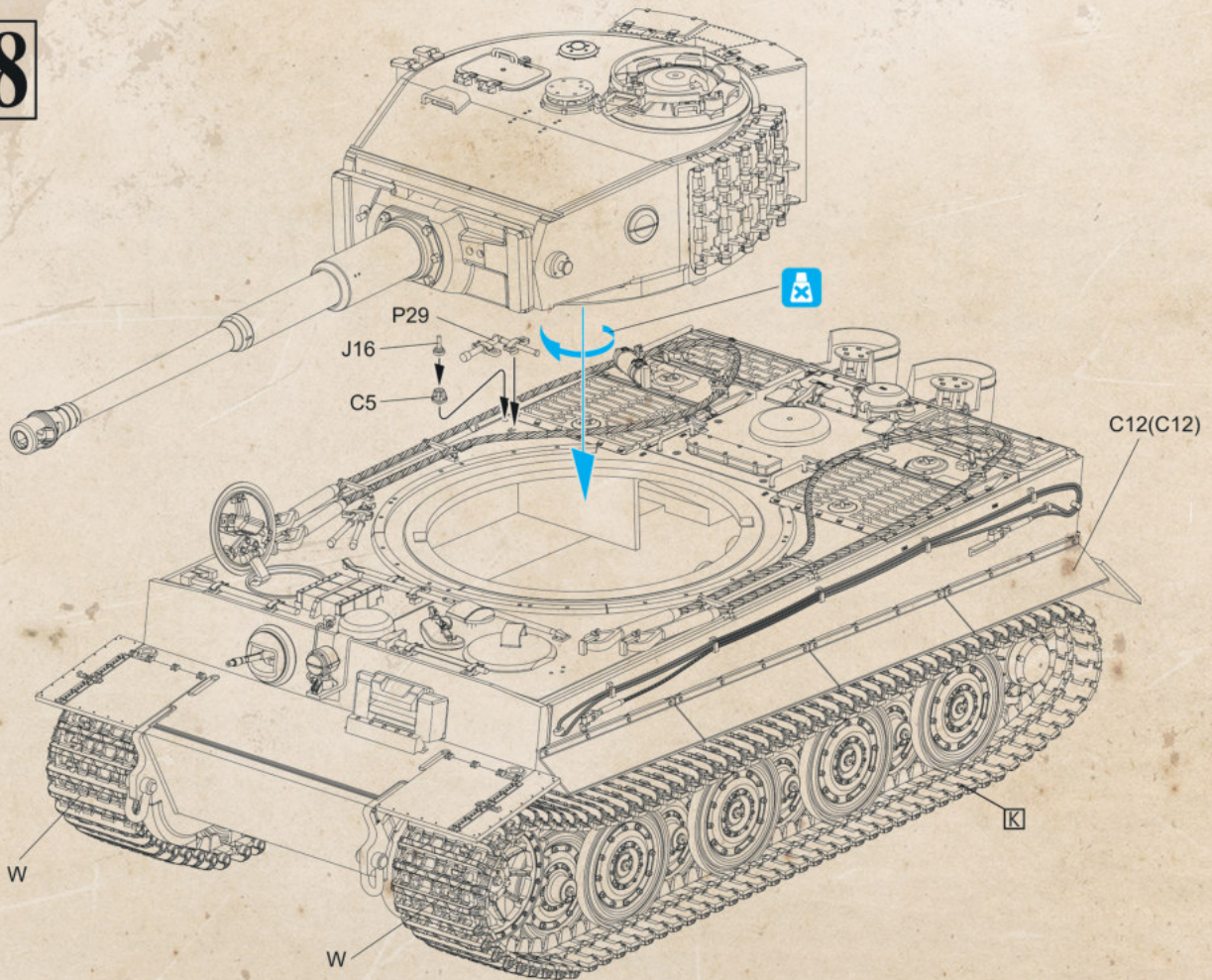

# Pz.Kpfw.VI Ausf.E Tiger I late

## Painting and Marking Guide

2./s.SS.Pz.Abt.101, June 1944, en route to Normandy

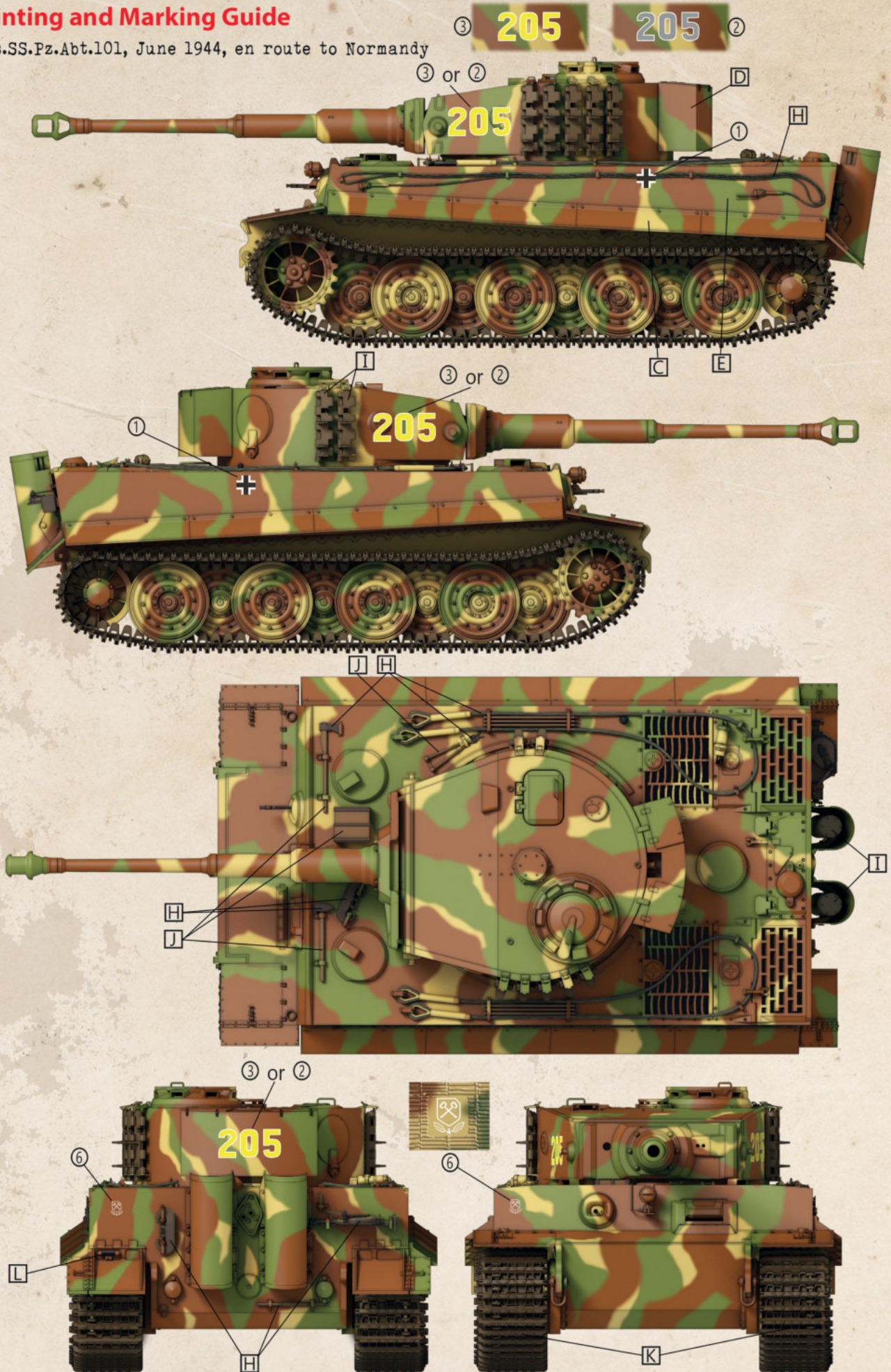

# Pz.Kpfw.VI Ausf.E Tiger I late

## Painting and Marking Guide

2./s.SS.Pz.Abt.101, June 1944, outside Villers-Bocage



# Pz.Kpfw.VI Ausf.E Tiger I late

## Painting and Marking Guide

sPz.Abt.507, April 1944, Podkomien, Russia



# Pz.Kpfw.VI Ausf.E Tiger I late

## Painting and Marking Guide

sPz.Abt.507, summer 1944, Russia

